



## **Assembly and operating Instructions**

### **Variable Area Flow Meters RA 65 / FA 65**



## Contents

1	Foreword .....	3
2	Safety .....	3
2.1	Symbol and meaning .....	3
2.2	General safety directions and exemption from liability .....	3
2.3	Intended use .....	4
2.4	Special safety instructions concerning glass devices .....	4
2.5	Information for Operator and operating personnel .....	4
2.6	Regulations and guidelines .....	4
2.7	Notice as required by the hazardous materials directive .....	5
3	Transport and storage .....	5
4	Installation .....	6
4.1	Work preparatory to installation .....	6
4.2	Preparation of the measuring device .....	6
4.3	Installation RA 65 .....	7
4.4	Installation FA 65 .....	7
5	Start-up .....	8
6	Readings in operation .....	8
7	Limit switches MSK1/MSK12/MSKW .....	9
7.1	Connection of limit switches .....	9
7.2	Setting the limit switches .....	10
8	Linear displacement sensor 4 .. 20 mA/0 ... 10V .....	11
8.1	Connection of the linear displacement sensor .....	11
8.2	Setting the sensor .....	12
9	Maintenance and cleaning of the flow meter .....	12
9.1	Dismantling and installation .....	12
9.2	Replacement of measuring glass .....	13
10	Service .....	14
10.1	Disposal .....	14
11	Technical data .....	15
11.1	Materials .....	15
11.2	Measuring ranges .....	16
11.3	Dimensions .....	17
11.4	Limit value switches MSK1/MSK12/MSKW .....	19
11.5	Right angle plug M12 x 1 .....	20
11.6	Linear displacement sensor .....	21
11.7	Low-Voltage Directive .....	22



## 1 Foreword

These Installation and Operating Instructions are applicable to devices of Series RA 65 and FA 65. Please follow all instructions and information given for installation, operation, inspection and maintenance. The Instructions form a component part of the device and should be kept in an appropriate place accessible to the personnel in the vicinity of the location. Where various plant components are operated together, the operating instructions pertaining to the other devices should also be observed.

## 2 Safety

### 2.1 Symbol and meaning



Safety notice

This symbol is placed against all directions/information relating to occupational health and safety in these Installation and Operating Instructions and draws attention to danger to life and limb. Such notices should be strictly observed.

### 2.2 General safety directions and exemption from liability

This document contains basic instructions for the installation, operation, inspection and maintenance of the variable area flow meter. Non-observance of these directions can lead to hazardous situations for man and beast and also to damage to property, for which Kirchner und Tochter disclaims all liability.

The operator is required to rule out potentially hazardous situations through voltage and released media energy.



## 2.3 Intended use

The series RA 65/FA 65 devices are variable area flow meters designed for liquids and gases and for installation in vertical pipe runs. Installation in the pipeline should be carried out solely in accordance with these Instructions. The required version of variable area flow meter should be selected on the basis of the pipe diameter at the point of use of the device. The limit values pertaining to the device are given in Section 11 and should not be exceeded. Modifications or other alterations to the flow meter may only be carried out by Kirchner und Tochter. Installation in horizontal pipe runs is possible using appropriate pipe bends. The direction of flow must always be from bottom to top. Details of the process product and the operating conditions are marked on the measuring glass.

## 2.4 Special safety instructions concerning glass devices



For safety reasons, we recommend fitting a protective shield in front of the measuring tube when starting up flow meters fitted with glass measuring tubes. The devices should not be operated where there is a risk of pressure surges (water hammer)!

To avoid glass breakage, all fitting work between measuring glass and heads inside the glass should be carried out by twisting and simultaneously pressing after having wetted the gaskets.

## 2.5 Information for Operator and operating personnel

Authorized installation, operating, inspection and maintenance personnel should be suitably qualified for the jobs assigned to them and should receive appropriate training and instruction. All persons charged with assembly, mounting, operation, inspection and maintenance duties must have read and understood the operating instructions. Gaskets in contact with the fluid product must be replaced after all maintenance and repair work.

## 2.6 Regulations and guidelines

In addition to the directions given in these Installation and Operating Instructions, observe the regulations, guidelines and standards, such as DIN EN and for specific applications, the codes of practice issued by DVGW (gas and water) and VdS (underwriters) or the equivalent national codes and applicable national accident prevention regulations.



## 2.7 Notice as required by the hazardous materials directive

In accordance with the law concerning handling of waste (critical waste) and the hazardous materials directive (general duty to protect), we would point out that all flow meters returned to Kirchner und Tochter for repair are required to be free from any and all hazardous substances (alkaline solutions, acids, solvents etc.).



Make sure that devices are thoroughly rinsed out to neutralize hazardous substances.

## 3 Transport and storage

Always use the original packing for transport, handling and storage. Protect the device against rough handling, coarse impact, jolts etc.



## 4 Installation

### 4.1 Work preparatory to installation

Preparation of the installation point:

- Check the pipe run at the point of installation. Variable area flow meters are only suitable for vertical installation and an upward flow direction (from bottom to top). For all other installation situations, appropriate pipe bends need to be fitted in the existing pipeline to ensure upward vertical flow through the device.
- The region of steady flow should be 4 to 6 x DN upstream and downstream of the location. Control equipment for gaseous media in particular should be installed downstream of the flow meter.
- If necessary, support the pipeline on both sides of the flow meter to prevent vibration from being transferred to the device.
- Before connecting, clean the pipelines leading to the device by blowing out or flushing.
- Prepare the installation point for the measuring device with appropriate pipe threads (RA 65) or flanges (FA 65) before beginning installation work. Pay attention to the correct spacing of the sealing faces and to exact alignment.
- Under no circumstances should the variable area flow meter be used to draw the pipe ends together (install free of stresses!). Do not over-tighten the union nuts.

### 4.2 Preparation of the measuring device

1. Remove the device from the transport packing.
2. Remove the transport protection stoppers from the ends of the device.
3. Pull the float securing rod out of the device (PVC red or grey).
4. Check that the float can move freely in the device.
5. Have ready: flat gaskets (FA 65) or packing material such as hemp (RA 65). These are not included with the supply.



### 4.3 Installation RA 65

1. Dismantle the inserts (item 9) and the union nuts (item 8) from the device.
2. Slip the union nuts over the ends of the pipeline at the installation point.
3. Screw the inserts on to the pipe ends together with packing material.
4. Slide the device with the gaskets (item 10) at both ends into the installation point.
5. Screw the union nuts back on to the device heads (item 2) and tighten them down such that the device is seated in the pipeline without stresses.

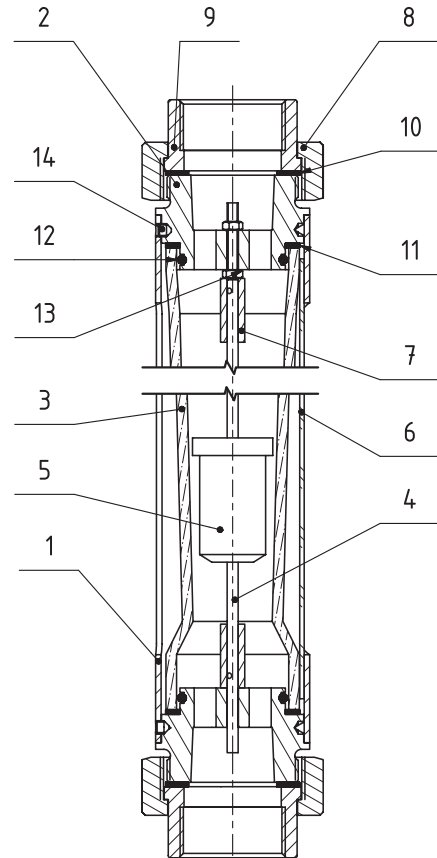

### 4.4 Installation FA 65

1. Slide the device together with the gaskets (not included with flow meter) at both ends (item 2) into the installation point.
2. Check that the gaskets are in alignment and make sure they do not project into the pipeline.
3. Fit the bolts and nuts of the flanged connection loosely.
4. Tighten bolts on the flanged connection in diagonally opposed sequence so that the device is fastened in the pipeline without stresses.

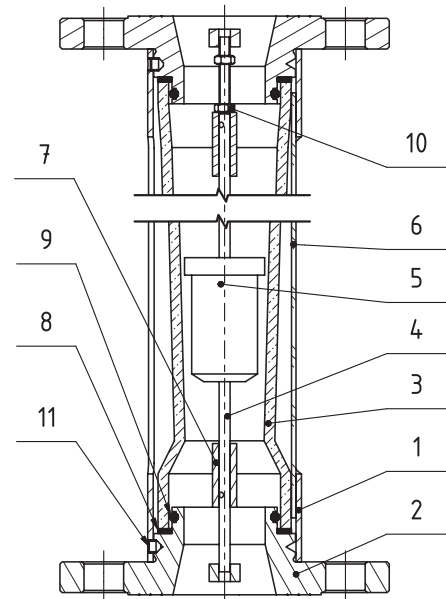



## 5 Start-up

The device must be properly installed before it is started up.

1. Check all device connections.
2. To set the flow: pressurize the pipelines by slowly opening the shut-off valves. On liquid service: carefully vent the pipeline.
3. Check the leak-tightness of all components and if necessary, tighten down threaded joints or screw connections.

## 6 Readings in operation

The flow value is read off from the scale on the glass cone at the top edge of the float. The measured-value readings are only correct when the operating condition at the measuring point (flowing medium, operating pressure and temperature) corresponds to the values marked on the measuring glass. If operating conditions should differ, the measured value must be corrected with the aid of the general float equation.

Information on theoretical basics and an conversion program can be found on our website: [www.kt-flow.de](http://www.kt-flow.de), section physics and calculations.





## 7 Limit switches MSK1/MSK12/MSKW

The flow meter can be equipped with limit switches to provide local indication with monitoring function.

The limit switches consist of a limit switch (reed switch) that is switched over by the magnet integrated in the float.

The limit switch is guided in a guide slot in the protective case and can be adjusted over the full measuring range. The reed switches have a bistable characteristic.

Uncontrolled current and voltage peaks can occur in the case of inductive or capacitive loads, e.g. from contactors or solenoid valves. Such peaks will also occur, depending on cable geometry, where cables exceed a certain length.

We therefore recommend using an MSR contact protection relay, which is additionally available. This will increase the contact rating and prevent occurrence of inductive and capacitive peaks, thus ensuring long service life of the contacts.

The electrical connection data and limit values must be observed in accordance with section 11.4.

### 7.1 Connection of limit switches



Electrical connection of the device must be carried out in conformity with the relevant VDE regulations (or equivalent national standards) and in accordance with the regulations issued by the local power supply utility.

1. Disconnect the plant from supply before connecting the limit switch.
2. Provide a protective circuit for the switches in keeping with their capacity.
3. Connect line-side fuse elements matched to consumption.
4. Connect the cable using the supplied right-angle plug (section 11.5).  
The circuit diagram for the limit switches is shown in the Technical Data (section 11.4).



## 7.2 Setting the limit switches

1. Loosen the knurled nut ⑥ on the neck of the switch ①.  
Device size 9,5: Loosen the locking screw ⑩ of the switch bracket ⑨.
2. Slide the switch ① to the flow value required to be monitored.
3. Please make sure the contact ① never touches the measuring glass ④ and the clearance between contact ① and glass ④ is always approx. 1 mm. This clearance can be obtained by turning the contact in the sliding block ⑦.
4. Test the switching characteristic by moving the float ⑤ over and beyond the switching position.
5. Retighten the knurled nut ⑥.  
Device size 9,5: Tighten the locking screw ⑩ of the switch bracket ⑨.



**The knurled nut ⑥ is always tightened by hand!  
Please do not use any tools!**

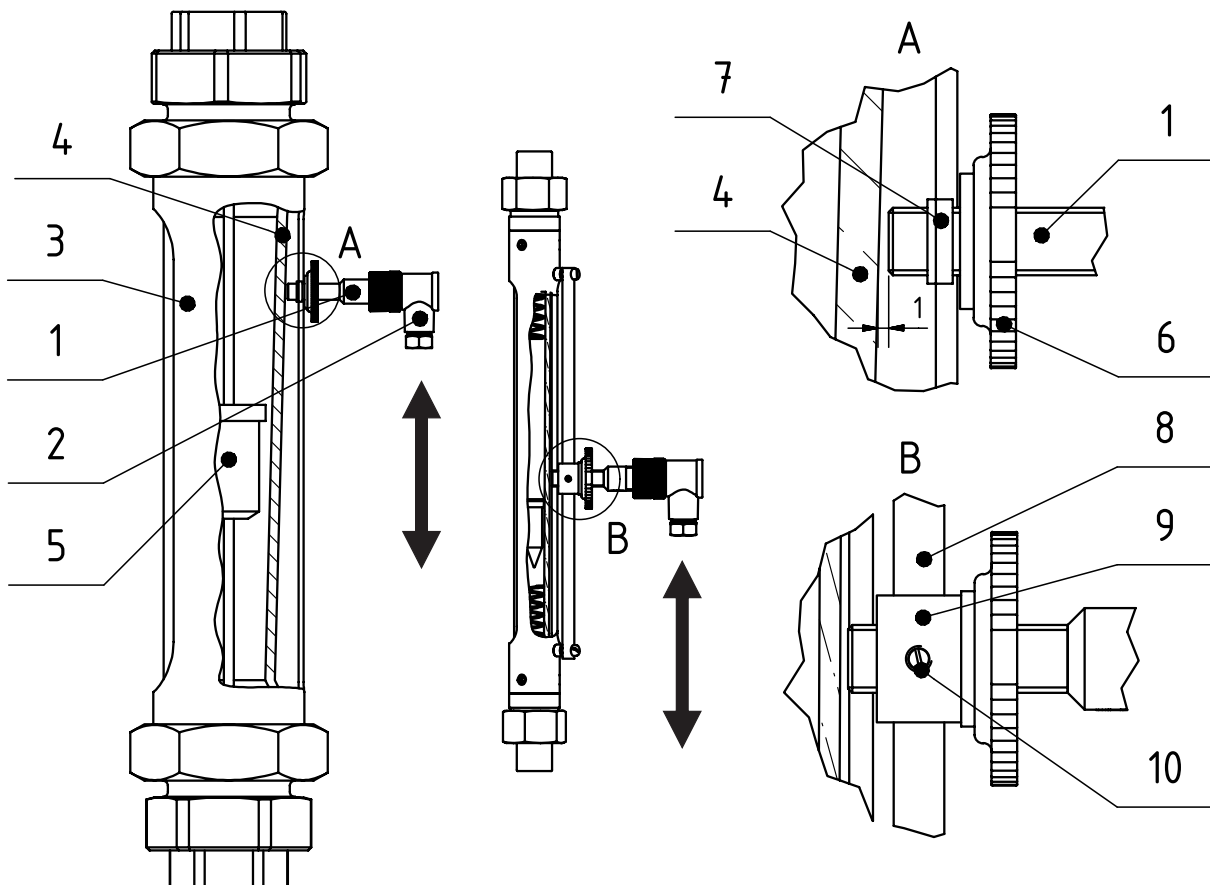

- ① MSK limit value switch
- ② M12 right angle plug
- ③ flow meter
- ④ measuring glass
- ⑤ float

- ⑥ knurled nut
- ⑦ sliding block
- ⑧ Switch rod
- ⑨ Switch bracket
- ⑩ Locking screw



## RA 65 / FA 65

Variable area flow meters

The linear displacement sensor, based on the Hall effect, delivers an output signal proportional to the height setting of the flow meter.

The signal can be displayed in 4 ... 20 mA or 0 ... 10 V and is used for remote flow rate observation. The sensor is connected via the enclosed M12 x 1 mm connector.

Please notice, that the sensor has a blind zone in the range of 3.7 mA to around 4 mA and performs stable operation only after approx. 4 mA.



The electrical connection of the device must be performed according to the pertinent VDE regulations, as well as the regulations of the local power company.

1. Disconnect electric power from the system before connecting the sensor.
2. Provide a protective circuit of the sensor corresponding to its output.
3. Connect the protective elements suitable for use upstream.
4. The cable connection is done on the enclosed angle connector. The circuit diagram for the sensor is in the following illustration:

Type	Circuit diagram	Pin assignment
4-wire		
2-wire		



## 8 Linear displacement sensor 4 .. 20 mA/0 ... 10V

The linear position sensor is delivered adjusted to the lowest measuring range point. This corresponds to an output signal of 4 mA.

The remaining measuring range or mA values can be taken from the supplied protocol.

If you want to move the 4 mA value to another measuring range point, move the sensor or the 4 mA value to the requested point.

To do this, loosen the two outer nuts with their lock washers. Next loosen the two stud screws by approximately one turn. Now you can move the sensor to the desired position and tighten the stud bolts and nuts again.

To record the new mA values, move the float to the desired scale lines and note the mA values.

### 8.1 Connection of the linear displacement sensor

The device is maintenance-free. Should the glass cone become fouled, the device can be removed from the pipeline as follows.

Remove the flow meter out of the system by detaching the union nuts or, as the case may be, the screw connections and/or pipe unions. After dismantling the upper head (detach the radial retaining screw), remove the measuring glass from the device and clean the individual parts. Reassemble in reverse order. Pay special attention to correct installation of the appropriate gaskets and the float stops. Before installing, inspect all gaskets (see pictures section 4.3 and 4.4) for signs of damage and replace if necessary.



## 8.2 Setting the sensor

1. Remove the device from the installation point. Detach the lateral retaining screws and remove the heads from the glass by simultaneously twisting and pulling them out of the glass. On devices with guide rod, leave the rod mounted on the upper head!
2. On devices with non-guided floats, remove the float stops and the float from the old glass.
3. Insert the float stops and the float into the new glass. Screw the float stops (helical springs made of VA steel) carefully with a pair of pliers into the glass ends (risk of glass breakage!).
4. Fit the device heads with new O-rings and gaskets.
5. Wet the O-ring before assembling glass and head.
6. Carefully slide the lower device head into the bottom opening of the measuring glass, twisting and pushing simultaneously (risk of glass breakage!).
7. Insert the glass with head into the case, making sure not to knock the glass against the case.
8. Fasten the device head with the retaining screws to the case.
9. Align the glass cone so that the inscriptions can be read off through the viewing window in the case.
10. Slide the second head with wetted O-ring by simultaneously twisting and pushing it into the upper opening of the measuring glass or steel case. Also lock the head in place on the case.
11. On devices with guide rod, check float mobility. If necessary, correct the position by turning the guide rod (to do this, hold the plain end of the guide rod at the lower head with a pair of engineer's pliers, or similar tool, and slightly loosen the M5 screw on the opposite side).
12. Reinstall the device in the installation point.

## 9 Maintenance and cleaning of the flow meter

### 9.1 Dismantling and installation



## 9.2 Replacement of measuring glass

All devices with defects or deficiencies should be sent directly to our repair department. In the service area of the Kirchner und Tochter homepage ([www.kt-flow.de](http://www.kt-flow.de)) you will find the declaration of decontamination as download and more information about returns.

To avoid risks to our employees and the environment, we can only process devices, for which we get a declaration of decontamination certifying that they are safe due to legal regulations. For questions, please contact our sales department, Tel. +49 2065-96090.

Refer to pictures in section 4.3 resp. 4.4

Please help to protect our environment and dispose workpieces in conformity with current regulations resp. continue using them.



**RA 65 / FA 65**

Variable area flow meters

## **10 Service**

### **10.1 Disposal**



## 11 Technical data

Nominal pressure rating	FA 65: PN 10 at 20 °C RA 65: PN 10 at 20 °C
Max. operating pressure	see table measuring ranges (section 11.2)
Thermal endurance	80 °C, optionally 100 °C
max. Umgebungstemperatur	90 °C
Turndown ratio	1:10
Accuracy class	VDE/VDI 3513 page 2 (08/2008)
Error limit (G)	1,6 %
Linear limit (qG)	50 %
Connection RA 65	two-part pipe union: Insert with cylindrical internal thread to DIN EN 10226-1 (ISO 7-1)
Connection FA 65	flange PN 10 acc. to DIN EN 1092-1, other connections on request
Corrosion protection	Epoxy powder coating, traffic blue (RAL 5017) glossy
Corrosion class	C3

### 11.1 Materials

Protective sleeve	precision steel tube made of P235
Heads RA 65	S355 (size 19 – 36), aluminium (size 43), optionally: PVC <sup>2)</sup>
Threaded joint	malleable cast iron zinc plated, optionally: PVC <sup>2)</sup>
Flanges FA 65	S355, optionally: with PVC inlay <sup>2)</sup>
Measuring glass	borosilicate glass
Splinter shield	perspex
Gaskets	standard: NBR, optionally FKM, EPDM, FFKM (Perlast)
Floats for liquids <sup>1)</sup>	standard: 1.4571 optionally: PVC, PP, PVDF or PTFE
Floats for gases <sup>1)</sup>	standard: Aluminium anodized optionally: PVC, PP, PTFE, PVDF or 1.4571
with limit value switches <sup>1)</sup>	liquids: 1.4571 with magnetic core gases: PVC with magnetic core
Special version <sup>2)</sup>	Corrosion protection of all parts in contact with the media

other materials on request

<sup>1)</sup> Floats of small sizes are non guided. Size 30 and larger: partly with guided float.  
Optionally sizes 9,5 (without limits switches only) and 19 are deliverable.  
A detailed table is available on request.

<sup>2)</sup> PVC lining: All wetted parts, except the measuring glass, are made from PVC.





### 11.2 Measuring ranges

Size	measuring range m <sup>3</sup> /h H <sub>2</sub> O				measuring range m <sup>3</sup> /h air at STP <sup>1)</sup>				max. operating pressure bar at 20 °C
9,5	0,5	–	5	l/h	8	–	80	l/h	10
	20	–	200	l/h	0,3	–	3,3	m <sup>3</sup> /h	
19	12	–	120	l/h	0,15	–	1,5	m <sup>3</sup> /h	10
	0,12	–	1,2	m <sup>3</sup> /h	1,6	–	16	m <sup>3</sup> /h	
30	0,1	–	1	m <sup>3</sup> /h	1,3	–	13	m <sup>3</sup> /h	10
	0,3	–	3	m <sup>3</sup> /h	3,6	–	36	m <sup>3</sup> /h	
36	0,4	–	4	m <sup>3</sup> /h	4	–	40	m <sup>3</sup> /h	8
	0,8	–	8	m <sup>3</sup> /h	8	–	80	m <sup>3</sup> /h	
43	0,9	–	9	m <sup>3</sup> /h	5	–	50	m <sup>3</sup> /h	8
	1,6	–	16	m <sup>3</sup> /h	16	–	160	m <sup>3</sup> /h	

measuring ranges for other substances and operating conditions on request

<sup>1)</sup> at STP: at standard conditions (0 °C and 1013 mbar abs.)



## 11.3 Dimensions

RA 65					
Size	Pipe fitting	SW	d <sup>1)</sup>	L	H
9,5	Rp ¼	28	12	308	25
	Rp ⅜	32	16	310	
	Rp ½	39	20	312	
19	Rp ½	39	20	413	45
	Rp ¾	48	25	420	
	Rp 1	55	32	424	
30	Rp 1	55	32	424	60
	Rp 1 ¼	67	40	428	
	Rp 1 ½	74	50	430	
36	Rp 1 ¼	67	40	428	70
	Rp 1 ½	74	50	430	
	Rp 2	90	63	445	
43	Rp 1 ½	74	50	430	90
	Rp 2	90	63	445	
	Rp 2 ½	111	75	446	
	Rp 3	131	90	450	

<sup>1)</sup> d for bonding and welding sleeves

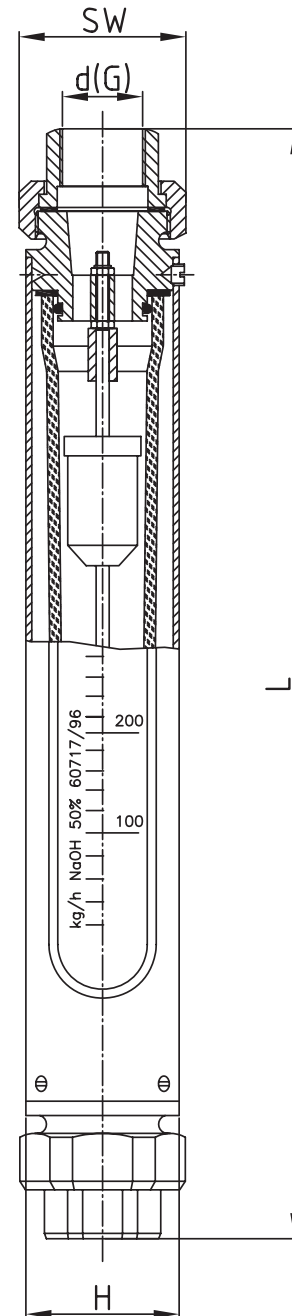



# RA 65 / FA 65

Variable area flow meters

Design	MSK1	MSK12
Switching voltage	0 ... 50 V AC/75 V DC	0 ... 50 V AC/75 V DC
Switching current	max. 0,5 A	max. 0,5 A
Switching capacity	max. 10 W/VA	max. 10 W/VA
Dielectric strength	230 V AC/400 V DC	230 V AC/400 V DC
Temperature range <sup>1)</sup>	-20 ... +90 °C	-20 ... +90 °C
Switching function	normally closed, bistable	normally open, bistable
Connection		
Design	MSKW	
Switching voltage	0 ... 100 V DC	
Switching current	max. 0,5 A	
Switching capacity	max. 5 W/ VA	
Dielectric strength	200 V DC	
Temperature range <sup>1)</sup>	-20 ... +90 °C	
Switching function	change over, bistable	
Connection		

<sup>3)</sup> TPlease note the temperature resistance of the flow meter/level indicator.  
Connection via freely configurable right angle plug M12 x 1

FA 65										
Size	DN	L	H	D	d <sub>4</sub>	k	Screws		d <sub>2</sub>	
							Qty	Thread		
9,5	10	260	25	90	40	60	4	M12	14	
	15			95	45	65	4	M12	14	
19	10	360	45	90	40	60	4	M12	M12	
	15			95	45	65	4	M12	14	
	20			105	58	75	4	M12	14	
	25			115	68	85	4	M12	14	
30	20	360	60	105	58	75		M12	M12	
	25			115	68	85	4	M12	14	
	40			150	88	110	4	M16	18	
36	25	360	70	115	68	85	4	M12	M12	
	40			150	88	110	4	M16	18	
	50			165	102	125	4	M16	18	
43	50	360	90	165	102	125	4	M16	18	
	65			185	122	145	4	M16	18	

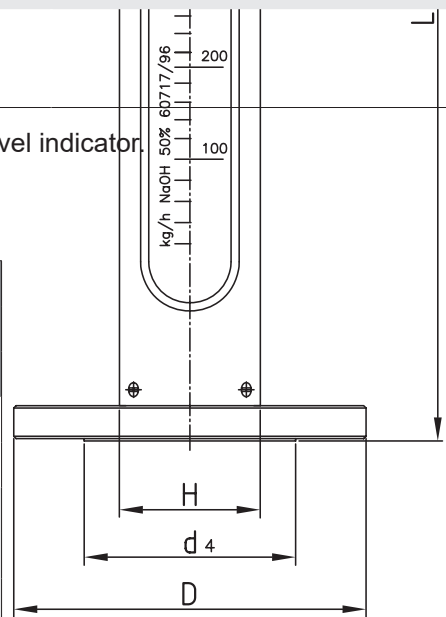



## 11.4 Limit value switches MSK1/MSK12/MSKW

M12 x 1 Right angle plug	
Connector	field-wireable female connector, M12 x 1, angled
Number of poles	4-pole, A-coding
Contacts	metal, CuZn, optalloy-plated
Contact carriers	plastic, PA, black
Grip	plastic, PBT, black
Seal	plastic, FKM
Degree of protection	IP67 only tightened with screws
External diameter of the cable	4 ... 6 mm
Core cross-section/ Clamping ability	max. 0,75 mm <sup>2</sup>
Screw-in thread	PG 7
Connection mode	screw clamp
Mechanical lifespan	min. 50 contact durability
Rated voltage	max. 250 V
Insulation resistance	≥ 10 <sup>8</sup> Ω
Ampacity	4 A
Forward resistance	≤ 8 mΩ
Ambient temperature	-25 ... +85 °C
Connector	

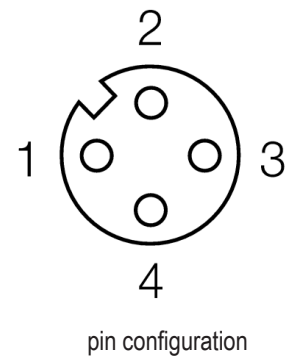
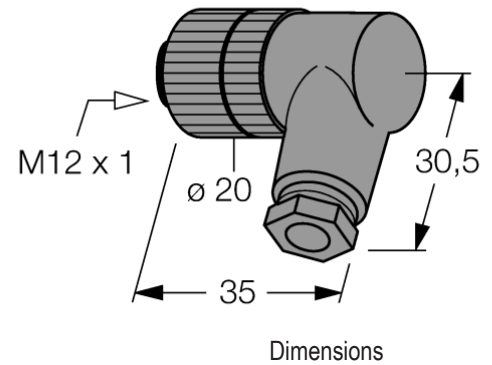



### 11.5 Right angle plug M12 x 1

Technical Data	4-wire	2-wire
Measurement range	125 mm / 160 mm	
Repeatability	≤ 0,1 % from measurement range ≤ dependent upon position sensor	
Linearity deviation	≤ 1 %	
Temperature drift	≤ ± 0,006 %/K	≤ ± 0,03 %/K
Ambient temperature <sup>1)</sup>	-25 ... +65 °C	
Operating voltage	15 ... 30 V DC	14 ... 30 V DC
Residual ripple	< 10 % U <sub>ss</sub>	
Idle current	≤ 15 mA	---
Rated insulation voltage	< 0.5 kV	
Short circuit protection	yes	
Fail-safe circuit/reverse polarity protection	yes/complete	
Output function	4-wire, analogue output	2-wire, analogue output
Voltage output / → Load resistance	0 ... 10 V / ≥ 4,7 kΩ	---
Current output / → Load resistance	4 ... 20 mA / ≤ 0,4 kΩ	4 ... 20 mA / ≤ [(U <sub>B</sub> - 14 V) / 20 mA] kΩ
Recovery time at output	< 15 ms	
Sampling rate	200 Hz	
Type	Rectangular, Q25L	
Dimensions	166 / 201 x 35 x 25 mm	
Housing material	Aluminium	
Material of active surface	Plastic, PC-GF20	
Vibration resistance	55 Hz (1 mm)	
Shock resistance	30g (11 ms)	
Protection class	IP67	
Approval acc. to	---	KEMA 03 ATEX 1122 X Issue no. 2
Device marking	---	⊕ II 2 G Ex ia IIC T6 Gb / II 2 D Ex ia IIIC T85 °C Db
LED, green	Power-on indication	
LED, yellow	float in measuring range	
LED, yellow flashing	float not in measuring range after power reset	
Connection	Plug Connector, M12 x 1	
Connection diagram		

<sup>1)</sup> The thermal endurance of the flow meter is crucial.



## 11.6 Linear displacement sensor

Above 50 V AC/75 V DC, contacts are subject to the EU Low Voltage Directive. The user is required to verify their use accordingly.





**Kirchner und Tochter**  
Durchflussmesstechnik seit 1951



The devices from **Kirchner und Tochter** have been tested in compliance with applicable EC/EU CE-regulations of the European Community.

The respective declaration of conformity is available on request. Subject to change without notice. The current valid version of our documents can be found at [www.kt-flow.de](http://www.kt-flow.de).

The **Kirchner und Tochter** QM-System is certified in accordance with DIN EN ISO 9001:2015. The quality is systematically adapted to the continuously increasing demands.