



Design and applications

The limit switches MSK1, MSK12 and MSKW are used for remote monitoring of measurement limits. They can be used in various Kirchner and Tochter model series.

The design consists of an M8 x 1 threaded sleeve and an angular coupling. The threaded sleeve contains a reed switch and a holding magnet. The holding magnet enables a bistable switching behaviour. The limit switch is actuated by a permanent magnet installed in the float. If it passes the limit switch, the contact switches.

The connection is made using a 4-pole M12 x 1 user-configurable right-angle plug made of PA and PBT.

Depending on the type of device, it is mounted either in a guide groove or a guide rod. The limit switches can be adjusted over the entire measuring range.

Both, variable area flowmeters and level gauges, can accommodate several limit switches. This enables monitoring of several measuring points.



- **Normally closed, normally open or changeover contact**
- **tool-free adjustment**
- **requires no power supply**
- **long lifetime**
- **reliable due to simple mode of operation**
- **can be used in potentially explosive areas**





MSK1 / MSK12 / MSKW

Limit value switches

Type series

MSK1	Brass housing (Normally closed, bistable)
MSK12	Brass housing (Normally open, bistable)
MSK1 VA	short, stainless steel housing (Normally closed, bistable)
MSK12 VA	short, stainless steel housing (Normally open, bistable)
MSKW VA	short, stainless steel housing (Changeover, bistable)
MSK1 PBT	short, plastic housing (Normally closed, bistable)
MSK12 PBT	short, plastic housing (Normally open, bistable)
MSKW PBT	short, plastic housing (Changeover, bistable)

Applicable in the following devices

Device type	Type
RA 60 / FA 60	Variable area flow meter
RA 65 / FA 65	Variable area flow meter
RA 77 / FA 77	Variable area flow meter
RA 87 / FA 87	Variable area flow meter
SGK 1 - 3	Variable area flow meter
DST	Bypass flowmeter
NA	Level indicator
NA-V4A	Level indicator

For further information please refer to the data sheet of the respective device type.

Materials limit value switch

Type series	Threaded sleeve	Washer	Nut *	Slot nut
MSK1/...12	CuZn nickel plated	PA	PA	stainless steel
MSK1/...12/...W VA	PBT, black	PA	PA	stainless steel
MSK1/...12/...W PBT	1.440	PA	PA	stainless steel

* Knurled nut; no tools are required for tightening.

PIN assignment Right angle connector

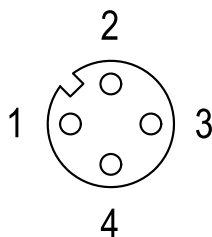

Technical data limit value switches

Design	MSK1 ...	MSK12 ...
Switching voltage	0 ... 50 V AC/75 V DC	0 ... 50 V AC/75 V DC
Switching current	max. 0,5 A	max. 0,5 A
Switching capacity	max. 10 W/VA	max. 10 W/VA
Dielectric strength	230 V AC/400 V DC	230 V AC/400 V DC
Temperature range ¹⁾	-20 ... +90 °C	-20 ... +90 °C
Switching function	normally closed, bistable	normally open, bistable
Connection		
Design	MSKW ...	
Switching voltage	0 ... 100 V DC	
Switching current	max. 0,5 A	
Switching capacity	max. 5 W/VA	
Dielectric strength	200 V DC	
Temperature range ¹⁾	-20 ... +90 °C	
Switching function	change over, bistable	
Connection		

¹⁾ Please note the temperature resistance of the flow meter/level indicator.

Technical Data

M12 x 1 Right angle connector	
Connector	field-wireable female connector, M12 x 1, angled
Number of poles	4-pole, A-coding
Contacts	metal, CuZn, optalloy-plated
Contact carriers	plastic, PA, black
Grip	plastic, PBT, black
Seal	plastic, FKM
Degree of protection	IP67 only tightened with screws
External diameter of the cable	4 ... 6 mm
Core cross-section/ Clamping ability	max. 0,75 mm ²
Screw-in thread	PG 7
Connection mode	screw clamp
Mechanical lifespan	min. 50 contact durability
Pollution degree	3
Rated voltage	max. 250 V
Insulation resistance	≥ 108 Ω
Ampacity	4 A
Forward resistance	≤ 8 mΩ
Ambient temperature Connector	-25 ... +85 °C

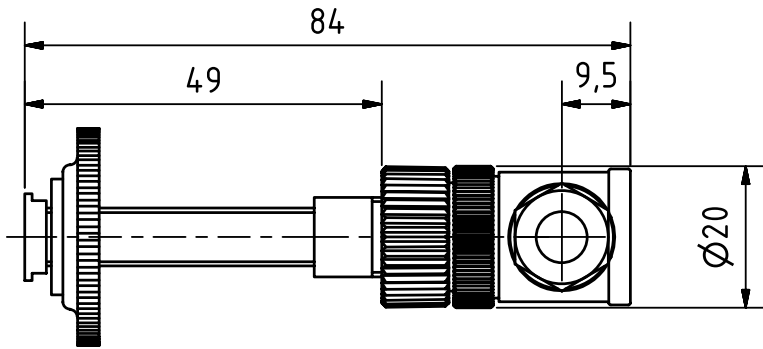

MSK1
MSK12

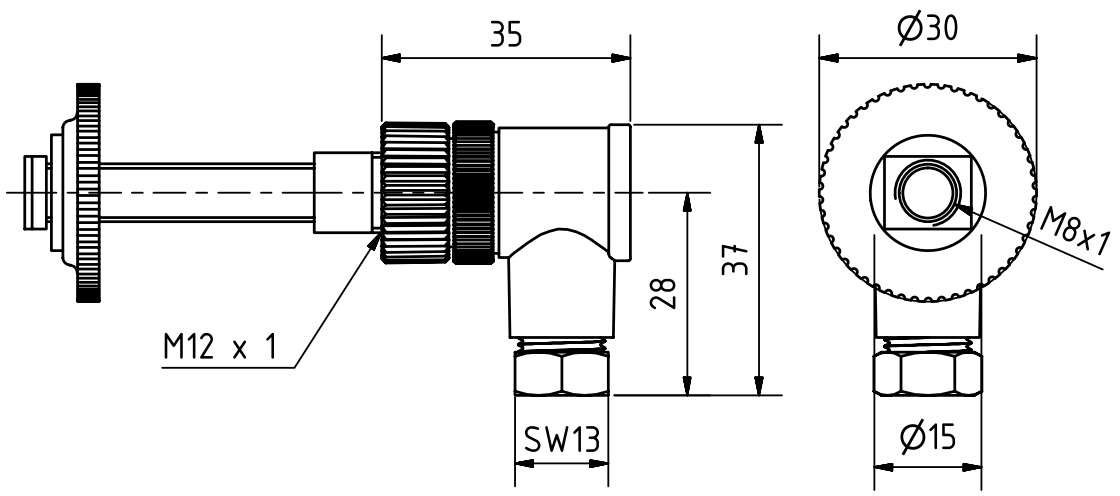

MSK1/ ...12/...W PBT

MSK1/ ...12/...W VA

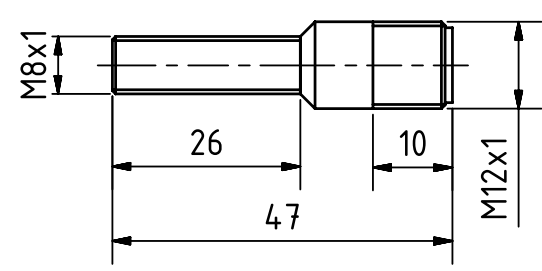
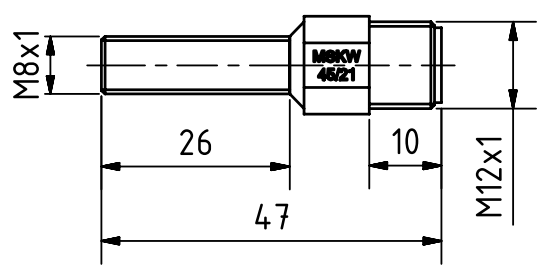
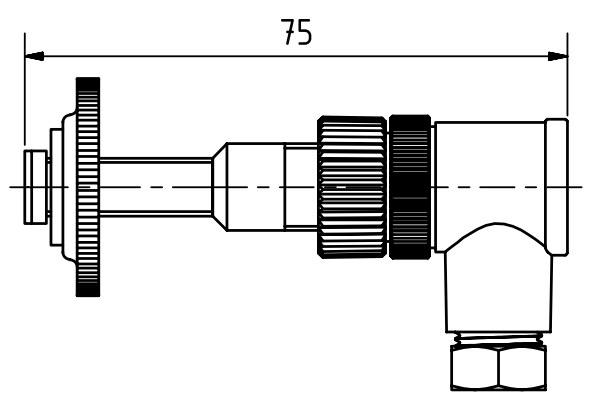
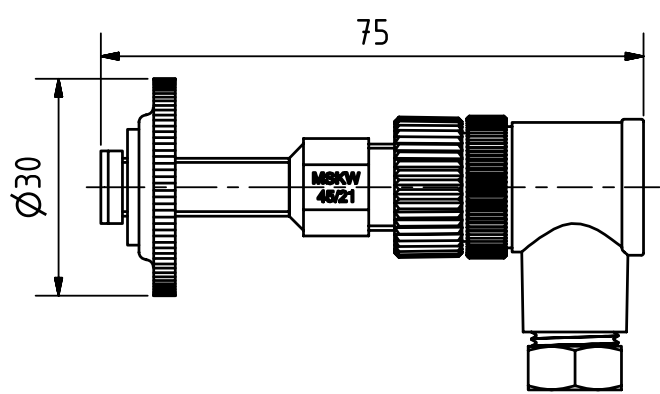



MSK1 / MSK12 / MSKW

Limit value switches

Limit value switch MSK1

The MSK1 limit value switch has the switching function of a break contact.

When the set limit value is exceeded, the installed reed switch opens the circuit. If the value falls below the limit value, the circuit closes again.

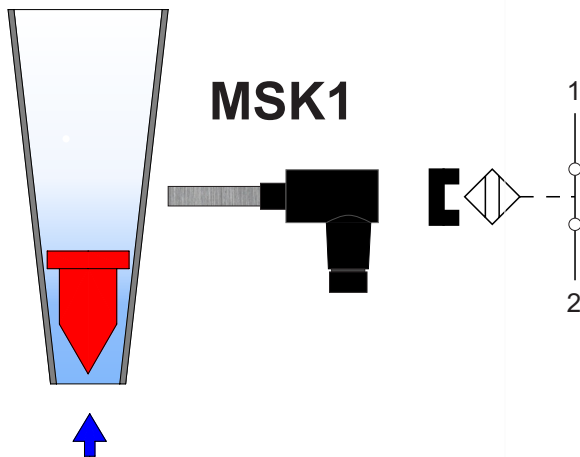

low flow rate: switch closed

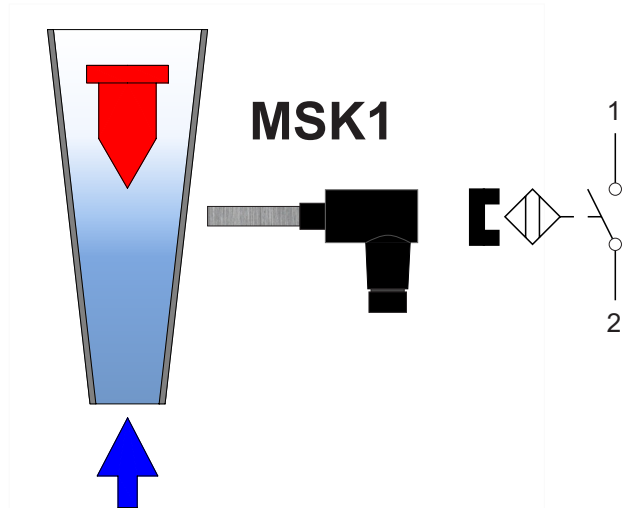

high flow rate: switch open

Limit value switch MSK12

The MSK12 limit value switch has the switching function of a normally open contact.

When the set limit value is exceeded, the installed reed switch closes the circuit. If the value falls below the limit value, the circuit opens again.

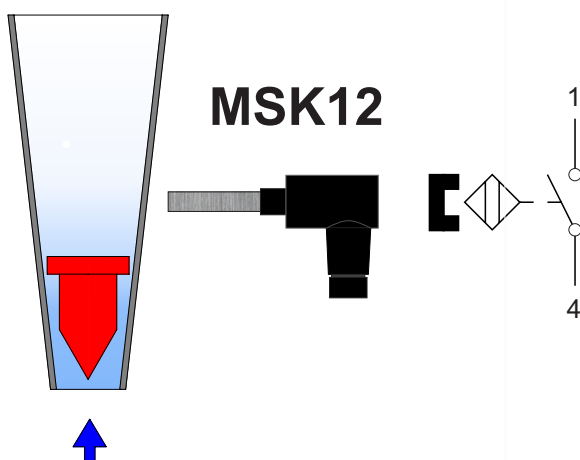

low flow rate: switch open

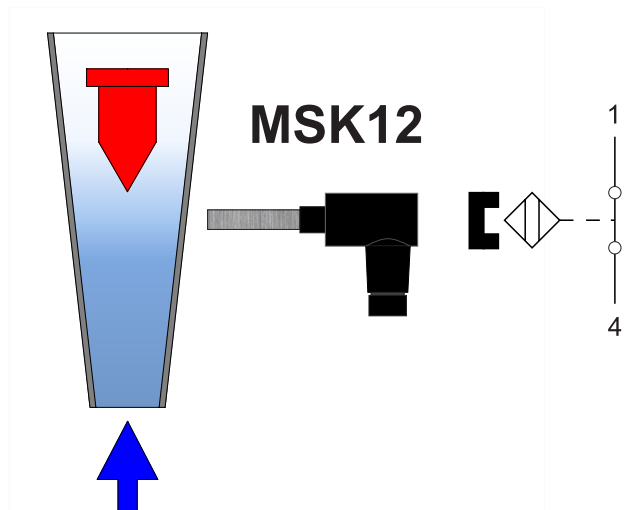

high flow rate: switch closed

Limit value switch MSKW

The MSKW limit value switch has the switching function of a changeover contact.

When the set limit value is exceeded, the installed reed switch closes the circuit between contacts 1 & 4. If the value falls below the limit value, the circuit between 1 & 2 closes.

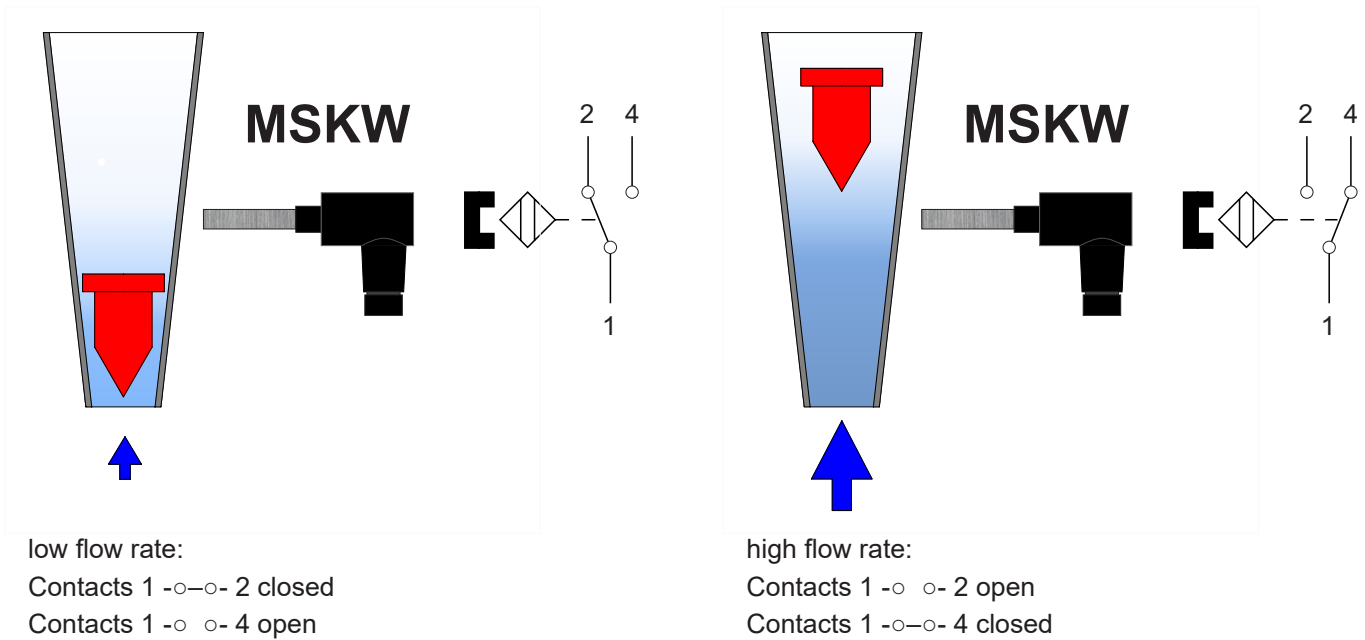



MSK1 / MSK12 / MSKW

Limit value switches

Low Voltage Directive

Above 50 V AC/75 V DC, electrical components are subjected to the EU Low Voltage Directive (LVD). The user is required to verify their use accordingly.

Application notes

With inductive or capacitive loads, e.g. by contactors or solenoid valves, uncontrollable current and voltage peaks can occur. Such peaks also occur in lines of a certain length or longer, depending on the geometry of the lines. It is therefore recommended to use an additionally available MSR contact protection relay. This increases the switching capacity and prevents the occurrence of inductive and capacitive peaks. It thus guarantees a long service life of the limit switches.

Proper use

The user is responsible for assessing the suitability of the flow meters for his case of application, for use as prescribed and for material compatibility as regards the fluid product used in his process.

The manufacturer shall not be liable for any damage arising from incorrect or improper use of the devices.

The equipment from **Kirchner und Tochter** has been tested in compliance with applicable CE-regulations of the European Community. The respective declaration of conformity is available on request. Subject to change without notice. The current valid version of our documents can be found at www.kt-flow.de.

The **Kirchner und Tochter** QM-System is certified in accordance with DIN EN ISO 9001:2015. The quality is systematically adapted to the continuously increasing demands.