

# **Assembly and operating Instructions**

**Sight glass fitting  
DN50–DN250**

**Visual indicator  
DN50**



## Contents

1	Foreword .....	3
2	Safety .....	3
2.1	Symbol and meaning .....	3
2.2	General safety directions and exemption from liability .....	3
2.3	Intended use .....	4
2.4	Special safety directions for glass devices .....	4
2.5	Information for Operator and operating personnel .....	4
2.6	Regulations and guidelines .....	4
2.7	Notice as required by the hazardous materials directive .....	5
3	Transport and storage .....	5
4	Installation .....	6
4.1	Preparing for Installation .....	6
4.2	Installation .....	6
5	Start-up .....	6
6	Maintenance and cleaning of the sight glass armature .....	7
6.1	Disassembly, replacement of parts .....	7
6.2	Assembly .....	8
7	Service .....	9
7.1	Disposal .....	9
8	Technical data .....	10
8.1	Materials .....	10
8.2	Type series .....	10
8.3	Working pressure .....	10
8.4	Dimensions .....	11
9	Special type visual indicator .....	12
10	Spare parts .....	14

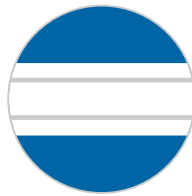

## 1 Foreword

These Installation and Operating Instructions are applicable to sight glass fittings in dimensions DN 50–DN 250 and the visual indicator DN50 with welding ends.

Please follow all instructions and information given for installation, operation, inspection and maintenance. The Instructions form a component part of the device and should be kept in an appropriate place accessible to the personnel in the vicinity of the location. Where various plant components are operated together, the operating instructions pertaining to the other devices should also be observed.

## 2 Safety

### 2.1 Symbol and meaning



Safety notice

This symbol is placed against all directions/information relating to occupational health and safety in these Installation and Operating Instructions and draws attention to danger to life and limb. Such notices should be strictly observed.

### 2.2 General safety directions and exemption from liability

This document contains basic instructions for the installation, operation, inspection and maintenance of the variable area flow meter. Non-observance of these directions can lead to hazardous situations for man and beast and also to damage to property, for which Kirchner und Tochter disclaims all liability.

The operator is required to rule out potentially hazardous situations through voltage and released media energy.



## 2.3 Intended use

The sight glass is a visual indicator for liquid media. The installation direction of the armature can be freely selected. The installation in the piping may only be made in accordance with these instructions. The limits of the device must be observed according to chapter 8. Any modifications or other changes to the sight glass may only be carried out by Kirchner und Tochter. Special safety instructions concerning glass devices.

## 2.4 Special safety directions for glass devices



For safety reasons, we recommend fitting a protective shield in front of the measuring tube when starting up flow meters fitted with glass measuring tubes. The devices should not be operated where there is a risk of pressure surges (water hammer)!

To avoid glass breakage, all fitting work between measuring glass and heads inside the glass should be carried out by twisting and simultaneously pressing after having wetted the gaskets.

## 2.5 Information for Operator and operating personnel

Authorized installation, operating, inspection and maintenance personnel should be suitably qualified for the jobs assigned to them and should receive appropriate training and instruction. All persons charged with assembly, mounting, operation, inspection and maintenance duties must have read and understood the operating instructions. Gaskets in contact with the fluid product must be replaced after all maintenance and repair work.

## 2.6 Regulations and guidelines

In addition to the directions given in these Installation and Operating Instructions, observe the regulations, guidelines and standards, such as DIN EN and for specific applications, the codes of practice issued by DVGW (gas and water) and VdS (underwriters) or the equivalent national codes and applicable national accident prevention regulations.

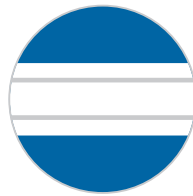

## 2.7 Notice as required by the hazardous materials directive

In accordance with the law concerning handling of waste (critical waste) and the hazardous materials directive (general duty to protect), we would point out that all flow meters returned to Kirchner und Tochter for repair are required to be free from any and all hazardous substances (alkaline solutions, acids, solvents etc.).



Make sure that devices are thoroughly rinsed out to neutralize hazardous substances.

## 3 Transport and storage

Always use the original packing for transport, handling and storage. Protect the device against rough handling, coarse impact, jolts etc.



## 4 Installation

### 4.1 Preparing for Installation

Preparing the mounting location:

- Optionally, the piping has to be supported in order to prevent the transmission of forces to the armature.
- The connecting pipes for the sight glass should be cleaned before connecting by blow or flush out.
- An appropriate place of installation must be provided for connection with flanges PN10 according to EN 1092-1. Pay attention to the correct distance from the sealing surfaces and in proper alignment.
- Under no circumstances should the line be drawn together by means of the sight glass (stress-free installation).

Preparation of the sight glass armature:

- Unpack the armature.
- Remove the transport protection caps at the ends of the armature.
- Keep matching seals for the flange connections in the delivered nominal diameter and nominal pressure PN10 according to EN 1092-1 as well as the necessary link material ready (not included).

### 4.2 Installation

Perform the flange connections between the armature and the flanges of the mounting location. To achieve the tightness all screws of the flange connections must be tightened crosswise. The sight glass armature may not catch any forces from the piping system and should be free of tension.

## 5 Start-up

The device must have been properly installed before it is started up.

Test the device connections.

Setting the flow: pressurize the pipelines by slowly opening the shutoff valves. In the case of liquids, make sure the pipeline is carefully vented.

Check the leak-tightness of all components and if necessary retighten threaded joints and bolted connections.

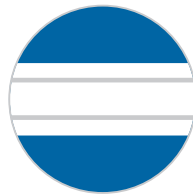

## **6 Maintenance and cleaning of the sight glass armature**

The device is maintenance-free. If the sight glass is dirty, it can be cleaned through the openings on the device ends after removal from the pipeline. Clean the glass after removal.

Do not use any aggressive cleaning agents (wire brush, abrasive cleaners, alkalis, acids, etc.). Avoid damage to the O-Rings. See chapter 4 for the installation of the cleaned sight glass armature.

### **6.1 Disassembly, replacement of parts**

Please note the safety instructions in chapter 2.

Please note that Kirchner und Tochter does not guarantee the leak proofness after disassembly.

Have the spare parts (chapter 10) ready for installation.

1. First dismantle the device from the installation site.
2. Place the sight glass vertically on a non-slip and level surface.
3. Loosen the cylinder head screws (5) on the upper flange (1).
4. Carefully lift the upper flange (1) from the glass tube (6).  
It is advisable to have a second person hold the glass tube.
5. Now carefully pull the glass tube (1) out of the lower flange.
6. Optional: Lay the lower flange together with the spacer rods (2) on its side and loosen the cylinder head screws.

Dispose of the defective or aged components properly.



## 6.2 Assembly

1. Optional: Insert the spacer rods (2) into the flange and tighten the Allen screws (5).
2. Place the flange (1) with the spacer rods (2) pointing vertically upwards on a non-slip and level surface.
3. Insert the new gaskets (3 and 4) into the lower flange.  
We recommend using only high-quality O-rings, such as our spare O-rings, and replacing them with new ones during assembly.  
This, together with professional installation, ensures that the fitting is leak-proof.
4. Moisten the glass tube and the O-ring seal (3) with a little water or glycerine (please note the material resistance of the O-rings and your system!) to simplify the installation of the glass tube.
5. Now carefully insert the glass tube vertically into the flange (1). Make sure that the O-rings do not slip out of their grooves.
6. Insert the new gaskets (3 and 4) into the upper flange. Do not reuse old gaskets! Please note point 4.
7. Now carefully place the upper flange (1) on the glass (6) and the spacer rods (2).
8. Insert the cylinder head screws (5) and tighten them.

Dispose of the defective or aged components properly.

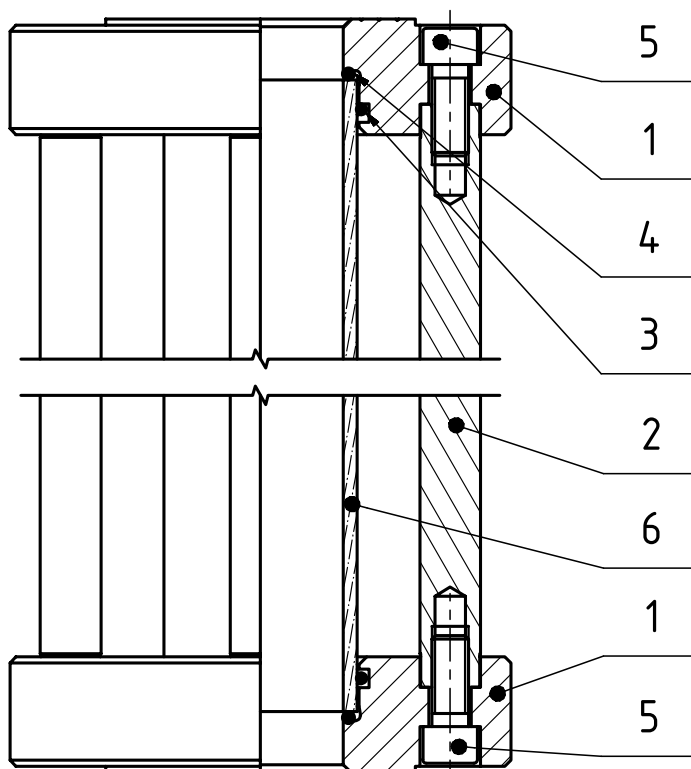



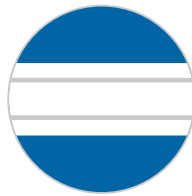

## **7 Service**

All devices with defects or deficiencies should be sent directly to our repair department. In the service area of the Kirchner und Tochter homepage ([www.kt-flow.de](http://www.kt-flow.de)) you will find the declaration of decontamination as download and more information about returns.

To avoid risks to our employees and the environment, we can only process devices, for which we get a declaration of decontamination certifying that they are safe due to legal regulations. For questions, please contact our sales department, Tel. +49 2065-96090.

### **7.1 Disposal**

Please help to protect our environment and dispose workpieces in conformity with current regulations resp. continue using them.



## 8 Technical data

max. working pressure	see table section 8.3
Temperature resistance <sup>1)</sup>	max. 70 °C, higher on request
Ambient Temperature	max. 70 °C
Connection	Flange PN 10 acc. DIN EN 1092-1, others on request
Corrosion protection	Epoxy powder coating, traffic blue (RAL 5017) glossy
Corrosion class	C3

<sup>1)</sup> media must not freeze

### 8.1 Materials

Type	SGL	SGL-V4A
Sight glass	borosilicate glass	borosilicate glass
Spacers	S355	1.4571 optionally: Hastelloy C4
Flanges	S355	1.4571 optionally: Hastelloy C4
Seals	NBR	NBR optionally: FKM

other materials on request

### 8.2 Type series

SGL	sight glass made of steel
SGL-V4A	sight glass made of stainless steel

### 8.3 Working pressure

DN	p max [bar]
50	8
65	9,7
80	8,2
100	6,4
125	5,2
150	4,2
200	3,6
250	2,6

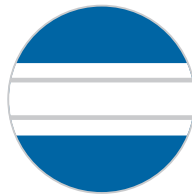

## 8.4 Dimensions

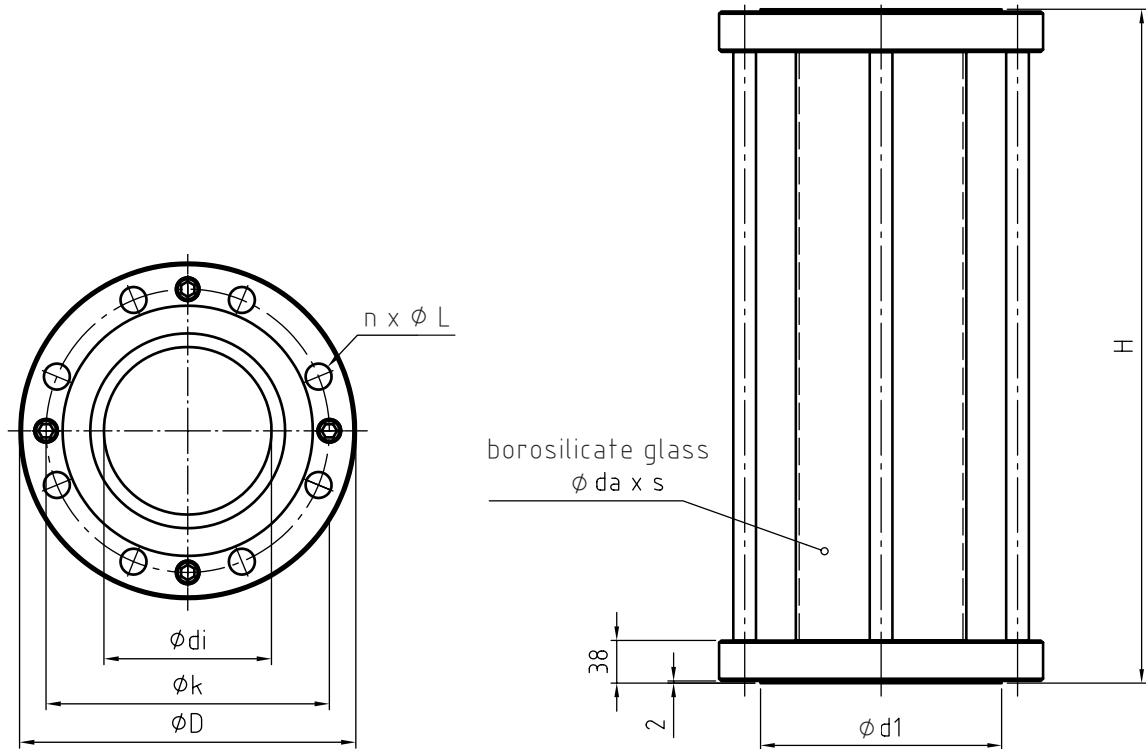

Flange connection PN10							Sight glass			p max [bar]
DN	Ø D	Ø k	d1	n	Ø L	H	Ø da	s	Ø di	
50	165	125	102	4	18	600	63,5	4,5	54,6	8
65	185	145	122	8	18	600	77	5	67	9,7
80	200	160	138	8	18	600	90	5	80	8,2
100	220	180	158	8	18	600	115	5	105	6,4
125	250	210	188	8	18	600	140	5	130	5,2
150	285	240	212	8	22	600	170	5	160	4,2
200	340	295	268	8	22	600	200	5	190	3,6
250	395	350	320	12	22	600	270	5	260	2,6

all dimensions in mm

other dimensions on request



## 9 Special type visual indicator

DN50 welding ends, size 36B

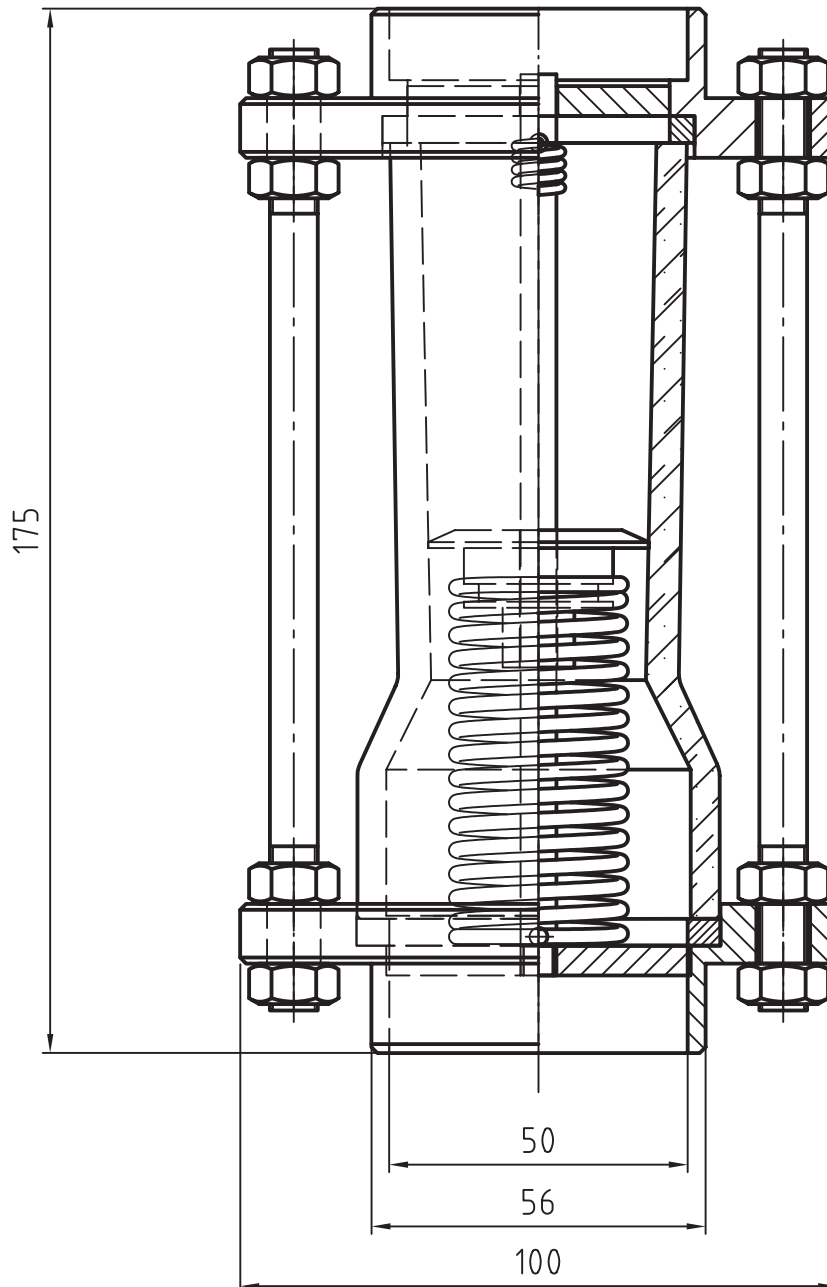

For further information on this design, please contact us.

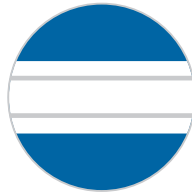

DN50 welding ends, size 30B

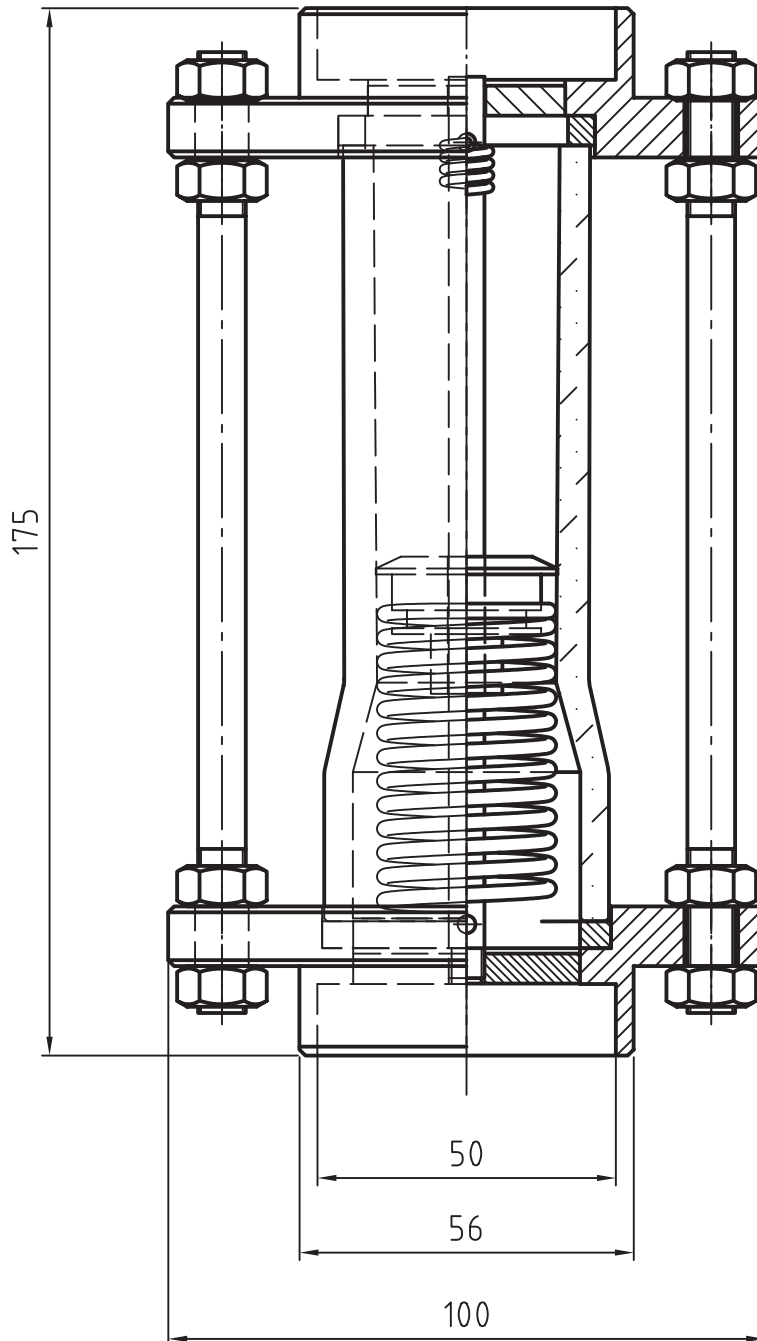

For further information on this design, please contact us.



## 10 Spare parts

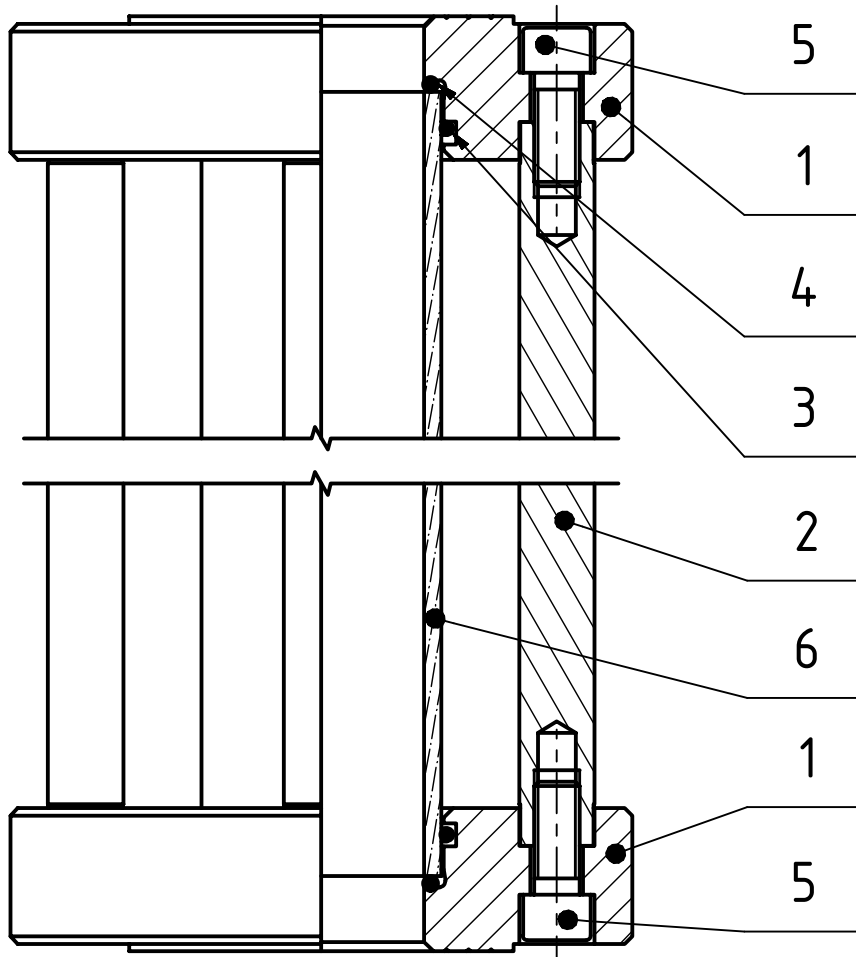

Item	Qty	Description
1	2	Flange
2	4	Spacer
3	2	O-ring for sealing
4	2	O-ring for bearing
5	8	Cylinder head screw
6	1	Glass tube





# Kirchner und Tochter

Durchflussmesstechnik seit 1951



The devices from **Kirchner und Tochter** have been tested in compliance with applicable EC/EU CE-regulations of the European Community.

The respective declaration of conformity is available on request. Subject to change without notice. The current valid version of our documents can be found at [www.kt-flow.de](http://www.kt-flow.de).

The **Kirchner und Tochter** QM-System is certified in accordance with DIN EN ISO 9001:2015. The quality is systematically adapted to the continuously increasing demands.