



Assembly and operating Instructions

Variable Area Flow Meters RA 77 / FA 77



Contents

1	Foreword	3
2	Safety	3
2.1	Symbol and meaning	3
2.2	General safety directions and exemption from liability	3
2.3	Special safety instructions concerning glass devices	4
2.4	Intended use	4
2.5	Information for Operator and operating personnel	4
2.6	Regulations and guidelines	4
2.7	Notice as required by the hazardous materials directive	5
3	Transport and storage	5
4	Installation	6
4.1	Work preparatory to installation	6
4.2	Preparation of the measuring device	6
4.3	Installation RA 77	7
4.4	Installation FA 77	8
5	Start-up	9
6	Readings in operation	9
7	Limit switches MSK1/MSK12/MSKW	10
7.1	Connection of limit switches	10
7.2	Setting the limit switches	11
8	Maintenance and cleaning of RA 77/FA 77	12
8.1	Dismantling and assembly	12
8.2	Replacement of measuring glass	12
9	Service	13
9.1	Disposal	13
10	Technical data	14
10.1	Materials	14
10.2	Measuring ranges	15
10.3	Dimensions	16
10.4	Limit value switches MSK1/MSK12/MSKW	18
10.5	M12 x 1 right angle plug	19
10.6	Low-Voltage Directive	19



1 Foreword

These Installation and Operating Instructions are applicable to devices of Series RA 77 and FA 77. Please follow all instructions and information given for installation, operation, inspection and maintenance. The Instructions form a component part of the device and should be kept in an appropriate place accessible to the personnel in the vicinity of the location. Where various plant components are operated together, the operating instructions pertaining to the other devices should also be observed.

2 Safety

2.1 Symbol and meaning



Safety notice

This symbol is placed against all directions/information relating to occupational health and safety in these Installation and Operating Instructions and draws attention to danger to life and limb. Such notices should be strictly observed.

2.2 General safety directions and exemption from liability

This document contains basic instructions for the installation, operation, inspection and maintenance of the variable area flow meter. Non-observance of these directions can lead to hazardous situations for man and beast and also to damage to property, for which Kirchner und Tochter disclaims all liability.

The operator is required to rule out potentially hazardous situations through voltage and released media energy.



2.3 Special safety instructions concerning glass devices



For safety reasons, we recommend fitting a protective shield in front of the measuring tube when starting up flow meters fitted with glass measuring tubes. The devices should not be operated where there is a risk of pressure surges (water hammer)!

To avoid glass breakage, all fitting work between measuring glass and heads inside the glass should be carried out by twisting and simultaneously pressing after having wetted the gaskets.

2.4 Intended use

The Series RA 77/FA 77 devices are a variable-area flow meters for liquids and gases. It is designed for installation in vertical pipe runs. Installation in the pipeline should be carried out solely in accordance with these Instructions. The required version of the variable area flowmeter should be selected on the basis of the pipe diameter at the installation location of the device. The limit values pertaining to the device are specified in section 10 and must be complied with. Any modifications or other alterations to the measuring device may be carried out solely by Kirchner und Tochter. Installation in horizontal pipe runs is possible using appropriate pipe bends. The direction of flow must always be from bottom to top. Details of the process product together with the operating conditions are marked on the measuring glass.

2.5 Information for Operator and operating personnel

Authorized installation, operating, inspection and maintenance personnel should be suitably qualified for the jobs assigned to them and should receive appropriate training and instruction. All persons charged with assembly, mounting, operation, inspection and maintenance duties must have read and understood the operating instructions. Gaskets in contact with the fluid product must be replaced after all maintenance and repair work.

2.6 Regulations and guidelines

In addition to the directions given in these Installation and Operating Instructions, observe the regulations, guidelines and standards, such as DIN EN and for specific applications, the codes of practice issued by DVGW (gas and water) and VdS (underwriters) or the equivalent national codes and applicable national accident prevention regulations.



2.7 Notice as required by the hazardous materials directive

In accordance with the law concerning handling of waste (critical waste) and the hazardous materials directive (general duty to protect), we would point out that all flow meters returned to Kirchner und Tochter for repair are required to be free from any and all hazardous substances (alkaline solutions, acids, solvents etc.).



Make sure that devices are thoroughly rinsed out to neutralize hazardous substances.

3 Transport and storage

Always use the original packing for transport, handling and storage. Protect the device against rough handling, coarse impact, jolts etc.



4 Installation

4.1 Work preparatory to installation

Preparation of the installation point:

- Check the pipe run at the point of installation. Variable area flow meters are only suitable for vertical installation and an upward flow direction (from bottom to top). For all other installation situations, appropriate pipe bends need to be fitted in the existing pipeline to ensure upward vertical flow through the device.
- The region of steady flow should be 4 to 6 x DN upstream and downstream of the location. Control equipment for gaseous media in particular should be installed downstream of the flow meter.
- If necessary, support the pipeline on both sides of the flow meter to prevent vibration from being transferred to the device.
- Before connecting, clean the pipelines leading to the device by blowing out or flushing.
- Prepare the installation point for the measuring device with appropriate pipe threads (RA 77) or flanges (FA 77) before beginning installation work. Pay attention to the correct spacing of the sealing faces and to exact alignment.
- On no account should the VA flow meter be used to pull the ends of the pipeline together (stress-free installation!). Do not over-tighten
- the union nuts

4.2 Preparation of the measuring device

1. Take the device out of the transport packaging.
2. Remove the transport protection plugs from the ends of the device.
3. Pull out the float security rod out of the device (PVC, red or grey).
4. Check that the float can move freely in the device.
5. Have ready a suitable adhesive for fixing the inserts to the pipe ends at the installation location.



4.3 Installation RA 77

1. Remove the insert (item 4) and the union nuts (item 6) from the device.
2. Slide the union nuts over the pipe ends at the installation location.
3. Stick the inserts using a suitable adhesive on to the pipe ends.
4. Slide the device between the two inserts in the installation location.
5. On meters with a guided float (item 7): 2 additional flat gaskets (item 10) are included with the meter. These should be inserted in the inserts before screwing on the union nuts or included during assembly. These prevent direct contact between the insert and the glass.
6. Screw the union nuts to the device sleeve (item 1) and tighten down so that the device is mounted without stresses in the pipeline.

Always tighten the nuts with the aid of a tool. Fingertight fastening of the union nuts is not sufficient to maintain leak tightness! For this purpose both union nuts must be held with a belt gripping tool or other suitable implement. Should the glass have twisted when tightening the nuts, lightly grease (pay attention to the resistance of the gasket material!) the gaskets at the ends of the glass.

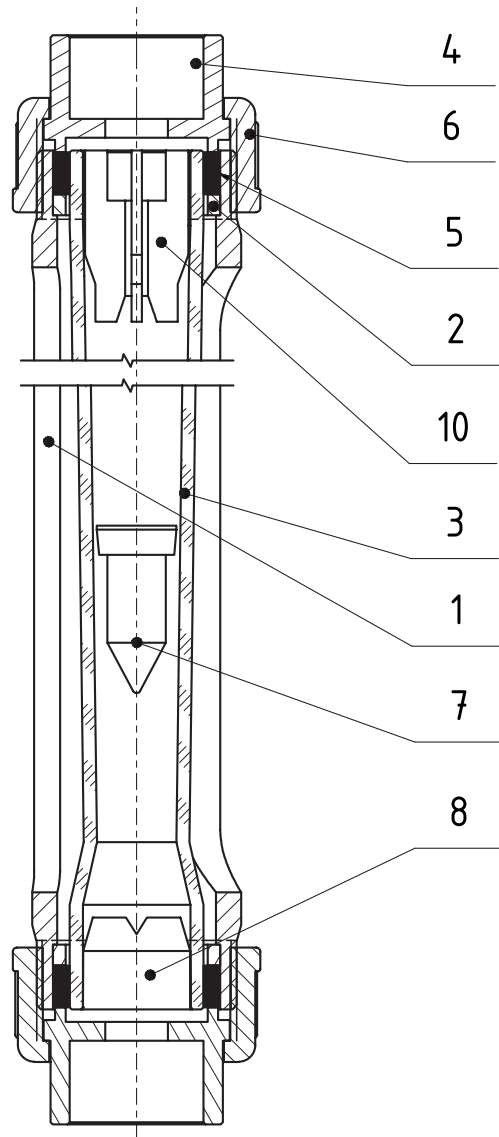



4.4 Installation FA 77

1. Slide the device together with the gaskets (not included with flow meter) at both ends (item 13) into the installation point.
2. Check that the gaskets are in alignment and make sure they do not project into the pipeline.
3. Fit the bolts and nuts of the flanged connection loosely (item 12).
4. Tighten bolts on the flanged connection in diagonally opposed sequence so that the device is fastened in the pipeline without stresses.

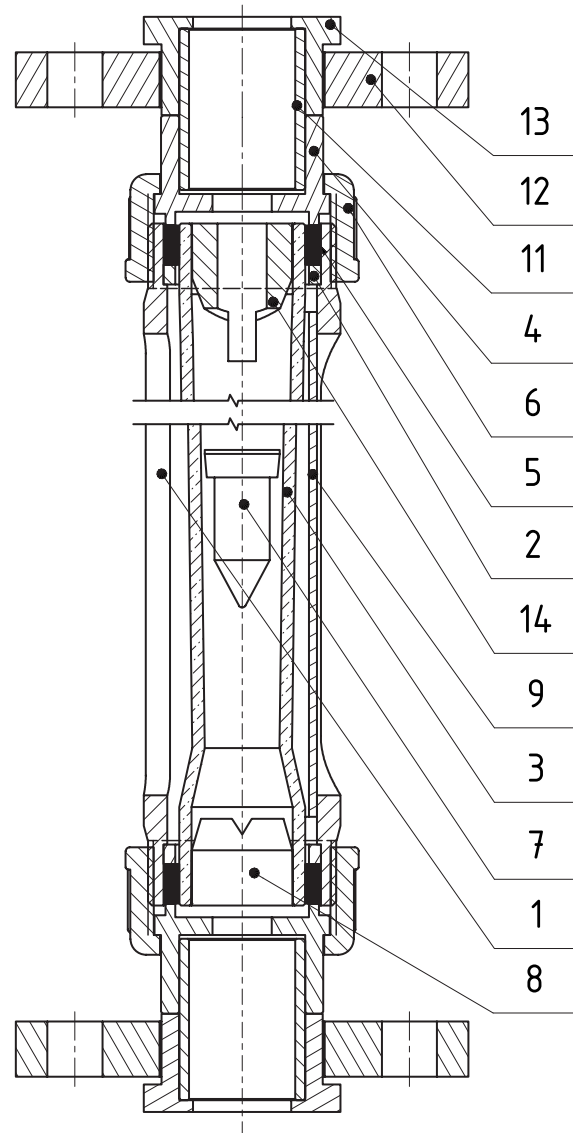



5 Start-up

The device must be properly installed before it is started up.

1. Check all device connections.
2. To set the flow: pressurize the pipelines by slowly opening the shut-off valves. On liquid service: carefully vent the pipeline.
3. Check the leak-tightness of all components and if necessary, tighten down threaded joints or screw connections.

6 Readings in operation

The flow value is read off from the scale on the glass cone at the top edge of the float. The measured-value readings are only correct when the operating condition at the measuring point (flowing medium, operating pressure and temperature) corresponds to the values marked on the measuring glass. If operating conditions should differ, the measured value must be corrected with the aid of the general float equation.

Information on theoretical basics and an conversion program can be found on our website: www.kt-flow.de, section physics and calculations.



7 Limit switches MSK1/MSK12/MSKW

The flow meter can be equipped with limit switches to provide local indication with monitoring function.

The limit switches consist of a limit switch (reed switch) that is switched over by the magnet integrated in the float.

The limit switch is guided in a guide slot in the protective case and can be adjusted over the full measuring range. The reed switches have a bistable characteristic.

Uncontrolled current and voltage peaks can occur in the case of inductive or capacitive loads, e.g. from contactors or solenoid valves. Such peaks will also occur, depending on cable geometry, where cables exceed a certain length.

We therefore recommend using an MSR contact protection relay, which is additionally available. This will increase the contact rating and prevent occurrence of inductive and capacitive peaks, thus ensuring long service life of the contacts.

7.1 Connection of limit switches



Electrical connection of the device must be carried out in conformity with the relevant VDE regulations (or equivalent national standards) and in accordance with the regulations issued by the local power supply utility.

1. Disconnect the plant from supply before connecting the limit switch.
2. Provide a protective circuit for the switches in keeping with their capacity.
3. Connect line-side fuse elements matched to consumption.
4. Connect the cable using the supplied right-angle plug. The circuit diagram for limit contacts is shown in the Technical Data, Section 10.4.



7.2 Setting the limit switches

1. Loosen the lock nut ⑥ SW13 (M8 x 1) on the neck of the switch ①.
2. Slide the switch ① to the flow value required to be monitored.
3. Please make sure the contact ① never touches the measuring glass ④ and the clearance between contact ① and glass ④ is always approx. 1 mm. This clearance can be obtained by turning the contact in the sliding block ⑦.
4. Test the switching characteristic by moving the float ⑤ over and beyond the switching position.
5. Retighten the lock nut ⑥. **Maximum fastening torque is 2 Nm!**

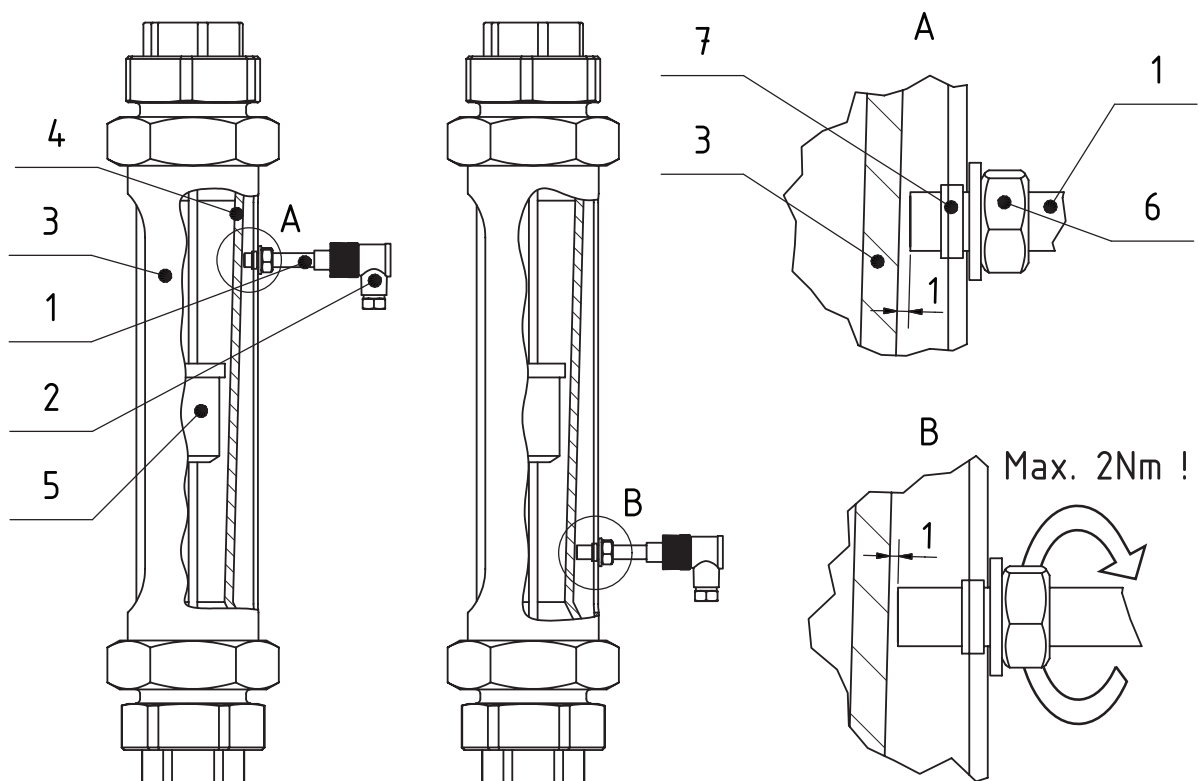

- ① MSK limit value switch
- ② M12 right angle plug
- ③ flow meter
- ④ measuring glass
- ⑤ float
- ⑥ lock nut
- ⑦ sliding block



8 Maintenance and cleaning of RA 77/FA 77

The device is maintenance-free. Should the glass cone become fouled, the device can be removed from the pipeline as follows.

8.1 Dismantling and assembly

Remove the flow meter out of the system by detaching the union nuts or, as the case may be, the screw connections and/or pipe unions. After dismantling the upper head, remove the measuring glass from the device and clean the individual parts. Reassemble in reverse order. Pay special attention to correct installation of the appropriate gaskets and the float stops. Before installing, inspect all gaskets (see picture in section 4.3 and 4.4) for signs of damage and replace if necessary.

8.2 Replacement of measuring glass

1. To dismantle the device, detach the union nut and take the device out of the installation point.
2. On devices with non-guided floats, remove the float stop and the float from the old glass and insert these into the new glass.
3. Fit new gaskets to the device heads.
4. Wet the sealing rings before assembling glass and head.
5. Insert the glass into the case, taking care not to knock the glass against the case.
6. Fasten the device head with the union nut to the case.
7. Align the glass cone so that the inscription can be read through the inspection window in the case.
8. Reinstall the flow meter.



9 Service

All devices with defects or deficiencies should be sent directly to our repair department. In the service area of the Kirchner und Tochter homepage (www.kt-flow.de) you will find the declaration of decontamination as download and more information about returns.

To avoid risks to our employees and the environment, we can only process devices, for which we get a declaration of decontamination certifying that they are safe due to legal regulations. For questions, please contact our sales department, Tel. +49 2065-96090.

9.1 Disposal

Please help to protect our environment and dispose workpieces in conformity with current regulations resp. continue using them.



10 Technical data

Nominal pressure rating and temperature resistance of the armature	PN 10 at 0 to +20 °C PVC: max. 6 bar at 40 °C PP: max. 1,5 bar at 80 °C PVDF: max. 5,5 bar at 80 °C
Max. operating pressure	see table of measuring ranges (section 10.2)
Measuring range	1:10
Accuracy class	VDE/VDI 3513 page 2 (08/2008)
Error limit (G)	1,6 %
Linear limit (qG)	50 %
Connection RA77	union nut and gluing sleeve acc. to DIN 8063, optionally thread acc. to DIN EN ISO 228 T1
Connection FA77	flange PN 10 acc. to DIN EN 1092-1, others on request

10.1 Materials

Protective tube	PVC-CAW-tube with insp. window, dark grey
Fittings and inserts RA 77	standard: PVC optionally: PP, PVDF
Flanges FA 77	standard: PVC optionally: PP, UP-GF
Measuring glass	borosilicate glass
Splinter shield	perspex
Gaskets	standard: EPDM optionally: FKM
Floats for liquids ¹⁾	standard: PVC red optionally: 1.4571, PP, PVDF
Floats for gases ¹⁾	standard: PVC red optionally: Aluminium anodized, PP, PVDF
With limit value switch	PVC red with magnetic core

other materials on request

¹⁾ Floats of small sizes are non guided. Size 30 and larger: partly with guided float. Optionally sizes 9,5 (without limits switches only) and 19 are deliverable. A detailed table is available on request.

²⁾ PVC lining: All wetted parts, except the measuring glass, are made from PVC.



10.2 Measuring ranges

Size	measuring range H ₂ O			measuring range HCL 30 %			measuring range Luft i.N. ¹⁾			max. operating pressure at 20 °C in bar
9,5	0,3 – 3 10 – 100	l/h l/h	0,3 – 3 10 – 100	l/h l/h	8 – 80 0,22 – 2,2	l/h m ³ /h	10			
10	0,1 – 1 15 – 150	l/h l/h	1 – 10 10 – 100	l/h l/h	0,3 – 3 0,25 – 2,5	l/h m ³ /h	10			
19	12 – 120 0,2 – 1,6	l/h m ³ /h	10 – 100 0,11 – 1,1	l/h m ³ /h	0,17 – 1,7 1,5 – 15	m ³ /h m ³ /h	10			
30	0,1 – 1 0,3 – 3	m ³ /h m ³ /h	90 – 900 0,28 – 2,8	l/h m ³ /h	1 – 10 3 – 30	m ³ /h m ³ /h	10			
36	0,35 – 3,5 0,6 – 6	m ³ /h m ³ /h	0,3 – 3 0,55 – 5,5	m ³ /h m ³ /h	3,6 – 36 7 – 70	m ³ /h m ³ /h	8			
43	0,6 – 6 3 – 16	m ³ /h m ³ /h	0,56 – 5,6 0,95 – 9,5	m ³ /h m ³ /h	6 – 60 12 – 120	m ³ /h m ³ /h	8			
100	1,5 – 15 2 – 20	m ³ /h m ³ /h	—		13 – 130 20 – 200	m ³ /h m ³ /h	5			

measuring ranges for other substances and operating conditions on request

¹⁾ at STP: at standard conditions (0 °C and 1013 mbar abs.)



10.3 Dimensions

RA 77						
Size	Glued DN	d	G	H	S	L
9,5	10	16	1/4	1	43	250
	15	20	3/8			
10	10	16	1/4	1	43	350
	15	20	3/8			
19	15	20	1/4	1 1/2	60	350
	20	25	3/8			
	25	32	1/2			
30	25	32	1	2 1/4	80	385
	32	40	1 1/4			
	40	50				
36	32	40	1 1/4	2 3/4	98	385
	40	50	1 1/2			
	50	63				
43	40	50	1 1/2	3 1/2	120	385
	50	63	2			
	65	75				
100	50	63	2	4 1/2	140 ¹⁾	385
	65	75	2 1/2			
	80	90	3			

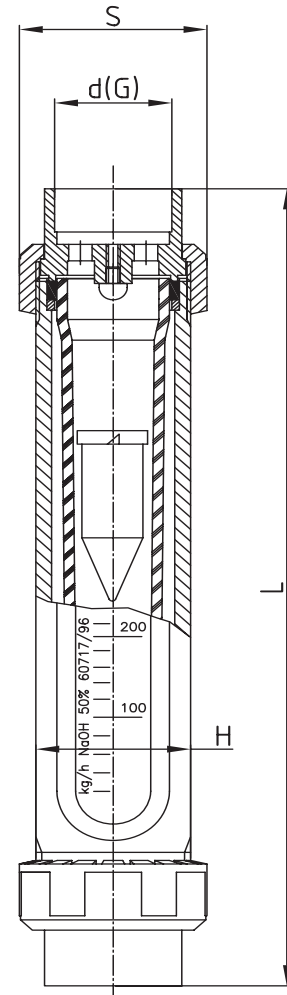

¹⁾ Union nut: Aluminium hexagonal



RA 77 / FA 77

Variable area flow meters

FA77										
Size	DN	d	d ₂	D	H	L	k	a	Screws Quantity	Thread
9,5	10	16	14	90	1	284	60	29	4	M 12
	15	20	14	95		288	65	34	4	M 12
10	10	16	14	90	1	384	60	29	4	M 12
	15	20	14	95		388	65	34	4	M 12
19	15	20	14	95	1 ½	388	65	34	4	M 12
	20	25	14	105		394	75	41	4	M 12
	25	32	14	115		400	85	50	4	M 12
30	25	32	14	115	2 ¼	435	85	50	4	M 12
	32	40	18	140		443	100	61	4	M 16
	40	50	18	150		453	110	73	4	M 16
36	32	40	18	140	2 ¾	443	100	61	4	M 16
	40	50	18	150		453	110	73	4	M 16
	50	63	18	165		467	125	90	4	M 16
43	40	50	18	150	3 ½	453	110	73	4	M 16
	50	63	18	165		467	125	90	4	M 16
	65	75	18	185		479	145	106	8	M 16
100	50	63	18	165	4 ½	467	125	90	4	M 16
	65	75	18	185		479	145	106	8	M 16
	80	90	18	200		497	160	125	8	M 16

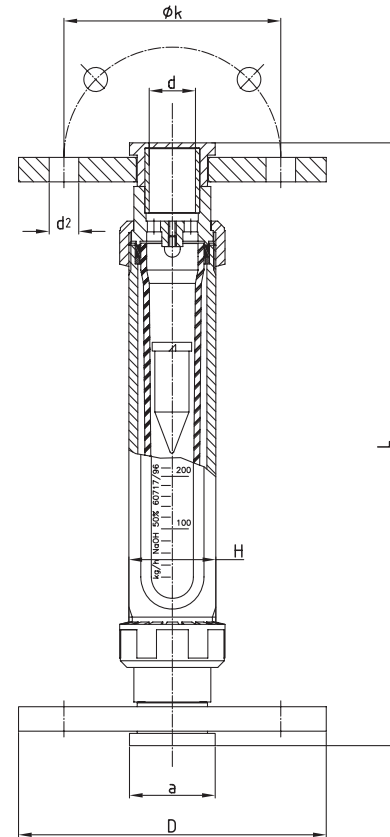

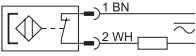
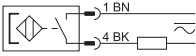
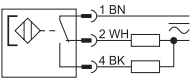

10.4 Limit value switches MSK1/MSK12/MSKW

Design	MSK1	MSK12
Switching voltage	50 V AC/75 V DC	50 V AC/75 V DC
Switching current	max. 0,5 A	max. 0,5 A
Switching capacity	max. 10 W/VA	max. 10 W/VA
Dielectric strength	230 V AC/400 V DC	230 V AC/400 V DC
Temperature range ¹⁾	-20 ... +90 °C	-20 ... +90 °C
Switching function	normally closed	normally open
Connection		
Design	MSKW	
Switching voltage	50 V AC/75 V DC	
Switching current	0,5 A	
Switching capacity	5 W/VA	
Dielectric strength	110 V AC/200 V DC	
Temperature range ¹⁾	-20 ... +90 °C	
Switching function	change over	
Connection		

¹⁾ The thermal endurance of the flow meter is crucial.

Connection via freely configurable right angle plug M12 x 1



10.5 M12 x 1 right angle plug

M12 x 1 Right angle plug	
Connector	field-wireable female connector, M12 x 1, angled
Number of poles	4-pole, A-coding
Contacts	metal, CuZn, optalloy-plated
Contact carriers	plastic, PA, black
Grip	plastic, PBT, black
Seal	plastic, FKM
Degree of protection	IP67 only tightened with screws
External diameter of the cable	4 ... 6 mm
Core cross-section/ Clamping ability	max. 0,75 mm ²
Screw-in thread	PG 7
Connection mode	screw clamp
Mechanical lifespan	min. 50 contact durability
Pollution degree	3
Rated voltage	max. 250 V
Insulation resistance	≥ 108 Ω
Ampacity	4 A
Forward resistance	≤ 8 mΩ
Ambient temperature	-25 ... +85 °C
Connector	

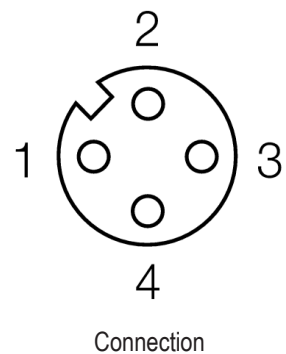
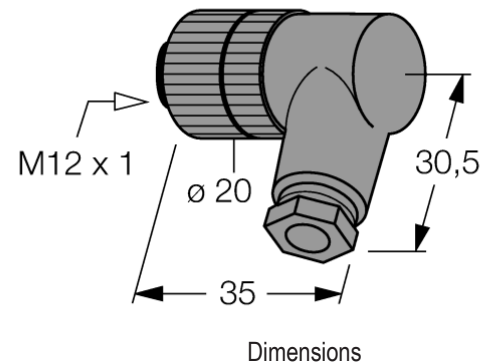

10.6 Low-Voltage Directive

Above 50 V AC/75 V DC, contacts are subject to the EU Low Voltage Directive. The user is required to verify their use accordingly.



Kirchner und Tochter
Durchflussmesstechnik seit 1951



The devices from **Kirchner und Tochter** have been tested in compliance with applicable EC/EU CE-regulations of the European Community.

The respective declaration of conformity is available on request. Subject to change without notice. The current valid version of our documents can be found at www.kt-flow.de.

The **Kirchner und Tochter** QM-System is certified in accordance with DIN EN ISO 9001:2015. The quality is systematically adapted to the continuously increasing demands.