



Assembly and operating Instructions

Variable Area Flow Meters RA 60 / FA 60



Contents

1	Foreword	3
2	Safety	3
2.1	Symbol and meaning	3
2.2	General safety directions and exemption from liability	3
2.3	Intended use	4
2.4	Special safety instructions concerning glass devices	4
2.5	Information for Operator and operating personnel	4
2.6	Regulations and guidelines	4
2.7	Notice as required by the hazardous materials directive	5
3	Transport and storage	5
4	Installation	6
4.1	Work preparatory to installation	6
4.2	Preparation of the measuring device	6
4.3	Installation RA 60	7
4.4	Installation FA 60	7
5	Start-up.....	8
6	Readings in operation.....	8
7	Limit switches MSK1/MSK12/MSKW	9
7.1	Connection of limit switches.....	9
7.2	Setting the limit switches.....	10
8	Linear displacement sensor 4 .. 20 mA/0 ... 10V	11
8.1	Connection of the linear displacement sensor	11
8.2	Adjusting the sensor.....	12
9	Maintenance and cleaning of the flow meter	13
9.1	Dismantling the glass cone RA 60	13
9.2	Assembling the glass cone RA 60.....	14
9.3	Replacement of the glass cone RA 60	14
9.4	Dismantling of the glass cone FA 60	15
9.5	Installation of the glass cone FA 60.....	15
9.6	Replacement of the glass cone FA 60.....	15
9.7	Subsequent installation of a float catcher protective cap.....	16
10	Service.....	18
11	Disposal.....	18
12	Technical data.....	19
12.1	Materials.....	19
12.2	Measuring ranges	20
12.3	Dimensions	21
12.4	Limit value switches MSK1/MSK12/MSKW	24
12.5	Right angle plug M12 x 1	25
12.6	Linear displacement sensor	26
12.7	Low-Voltage Directive	26



1 Foreword

These Installation and Operating Instructions are applicable to devices of Series RA 60 and FA 60. Please follow all instructions and information given for installation, operation, inspection and maintenance. The Instructions form a component part of the device and should be kept in an appropriate place accessible to the personnel in the vicinity of the location. Where various plant components are operated together, the operating instructions pertaining to the other devices should also be observed.

2 Safety

2.1 Symbol and meaning



Safety notice

This symbol is placed against all directions/information relating to occupational health and safety in these Installation and Operating Instructions and draws attention to danger to life and limb. Such notices should be strictly observed.

2.2 General safety directions and exemption from liability

This document contains basic instructions for the installation, operation, inspection and maintenance of the variable area flow meter. Non-observance of these directions can lead to hazardous situations for man and beast and also to damage to property, for which Kirchner und Tochter disclaims all liability.

The operator is required to rule out potentially hazardous situations through voltage and released media energy.



2.3 Intended use

The Series RA 60/FA 60 device is a variable area flow meter designed for liquids and gases and for installation in vertical pipe runs. Installation in the pipeline should be carried out solely in accordance with these Instructions. The required version of variable area flow meter should be selected on the basis of the pipe diameter at the point of use of the device. The limit values pertaining to the device are given in section 12 and should not be exceeded. Modifications or other alterations to the flow meter may only be carried out by Kirchner und Tochter. Installation in horizontal pipe runs is possible using appropriate pipe bends. The direction of flow must always be from bottom to top. Details of the process product and the operating conditions are marked on the measuring glass.

2.4 Special safety instructions concerning glass devices



For safety reasons, we recommend fitting a protective shield in front of the measuring tube when starting up flow meters fitted with glass measuring tubes. The devices should not be operated where there is a risk of pressure surges (water hammer)!

To avoid glass breakage, all fitting work between measuring glass and heads inside the glass should be carried out by twisting and simultaneously pressing after having wetted the gaskets.

2.5 Information for Operator and operating personnel

Authorized installation, operating, inspection and maintenance personnel should be suitably qualified for the jobs assigned to them and should receive appropriate training and instruction. All persons charged with assembly, mounting, operation, inspection and maintenance duties must have read and understood the operating instructions. Gaskets in contact with the fluid product must be replaced after all maintenance and repair work.

2.6 Regulations and guidelines

In addition to the directions given in these Installation and Operating Instructions, observe the regulations, guidelines and standards, such as DIN EN and for specific applications, the codes of practice issued by DVGW (gas and water) and VdS (underwriters) or the equivalent national codes and applicable national accident prevention regulations.



2.7 Notice as required by the hazardous materials directive

In accordance with the law concerning handling of waste (critical waste) and the hazardous materials directive (general duty to protect), we would point out that all flow meters returned to Kirchner und Tochter for repair are required to be free from any and all hazardous substances (alkaline solutions, acids, solvents etc.).



Make sure that devices are thoroughly rinsed out to neutralize hazardous substances.

3 Transport and storage

Always use the original packing for transport, handling and storage. Protect the device against rough handling, coarse impact, jolts etc.



4 Installation

4.1 Work preparatory to installation

Preparation of the installation point:

- Check the pipe run at the point of installation. Variable area flow meters are only suitable for vertical installation and an upward flow direction (from bottom to top). For all other installation situations, appropriate pipe bends need to be fitted in the existing pipeline to ensure upward vertical flow through the device.
- The region of steady flow should be 4 to 6 x DN upstream and downstream of the location. Control equipment for gaseous media in particular should be installed downstream of the flow meter.
- If necessary, support the pipeline on both sides of the flow meter to prevent vibration from being transferred to the device.
- Before connecting, clean the pipelines leading to the device by blowing out or flushing.
- Prepare the installation point for the measuring device with appropriate pipe threads (RA 60) or flanges (FA 60) before beginning installation work. Pay attention to the correct spacing of the sealing faces and to exact alignment.
- Under no circumstances should the variable area flow meter be used to draw the pipe ends together (install free of stresses!). Do not over-tighten the union nuts.

4.2 Preparation of the measuring device

1. Remove the device from the transport packing.
2. Remove the transport protection stoppers from the ends of the device.
3. Pull the float securing rod out of the device (PVC red or grey).
4. Check that the float can move freely in the device.
5. Have ready: flat gaskets (FA 60) or packing material such as hemp (RA 60). These are not included with the supply.



4.3 Installation RA 60

1. Remove the insert (item 1) and the union nuts (item 3) from the device.
2. Slip the union nuts over the ends of the pipeline at the installation point.
3. Screw the inserts using packing material (e.g. hemp) to the ends of the pipeline.
4. Slide the device together with the flat gaskets (item 2) on both ends into the installation point.
5. Screw the union nuts (item 3) on to the device heads (item 4) and tighten them so that the device is positioned in the pipeline free of stresses.

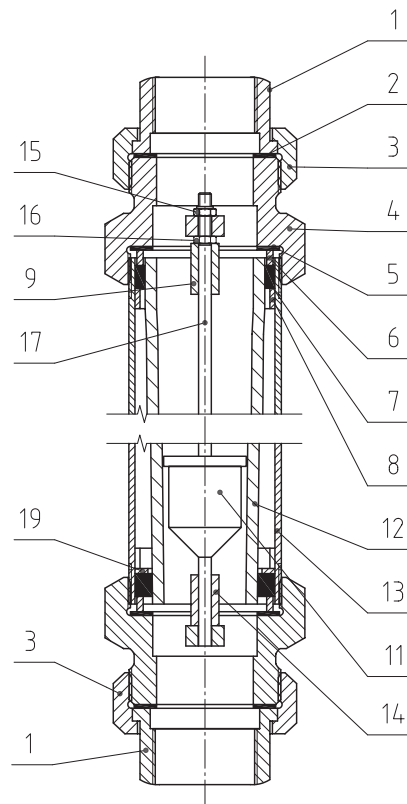

4.4 Installation FA 60

1. Slide the device together with the flat gaskets (not included with supply) at both ends (item 1) into the installation point.
2. Check that the flat gaskets are in alignment and do not project into the pipeline.
3. Fit the bolts and nuts of the flanged connection loosely.
4. Tighten the bolted connection between customer-supplied flange and item 1 in diagonally opposite sequence so that the device is fixed free of stresses in the pipeline.

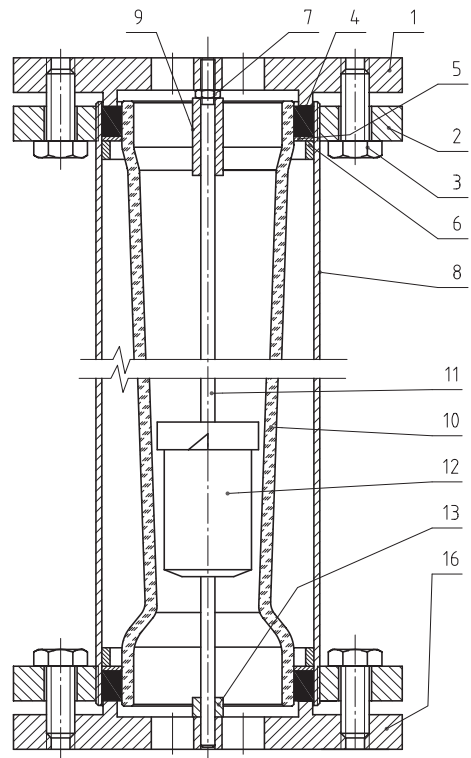



5 Start-up

The device must be properly installed before it is started up.

1. Check all device connections.
2. To set the flow: pressurize the pipelines by slowly opening the shut-off valves. On liquid service: carefully vent the pipeline.
3. Check the leak-tightness of all components and if necessary, tighten down threaded joints or screw connections.

6 Readings in operation

The flow value is read off from the scale on the glass cone at the top edge of the float. The measured-value readings are only correct when the operating condition at the measuring point (flowing medium, operating pressure and temperature) corresponds to the values marked on the measuring glass. If operating conditions should differ, the measured value must be corrected with the aid of the general float equation.

Information on theoretical basics and an conversion program can be found on our website: www.kt-flow.de, section physics and calculations.



7 Limit switches MSK1/MSK12/MSKW

The flow meter can be equipped with limit switches to provide local indication with monitoring function.

The limit switches consist of a limit switch (reed switch) that is switched over by the magnet integrated in the float.

The limit switch is guided in a guide slot in the protective case and can be adjusted over the full measuring range. The reed switches have a bistable characteristic.

Uncontrolled current and voltage peaks can occur in the case of inductive or capacitive loads, e.g. from contactors or solenoid valves. Such peaks will also occur, depending on cable geometry, where cables exceed a certain length.

We therefore recommend using an MSR contact protection relay, which is additionally available. This will increase the contact rating and prevent occurrence of inductive and capacitive peaks, thus ensuring long service life of the contacts.

The electrical data and limit values must be observed in accordance with section 12.4.

7.1 Connection of limit switches



Electrical connection of the device must be carried out in conformity with the relevant VDE regulations (or equivalent national standards) and in accordance with the regulations issued by the local power supply utility.

1. Disconnect the plant from supply before connecting the limit switch.
2. Provide a protective circuit for the switches in keeping with their capacity.
3. Connect line-side fuse elements matched to consumption.
4. Connect the cable using the supplied right-angle plug ② (section 12.5). The circuit diagram for the limit switches is shown in the Technical Data (section 12.4).



7.2 Setting the limit switches

1. Loosen the lock nut ⑥ SW13 (M8 x 1) on the neck of the switch ①.
2. Slide the switch ① to the flow value required to be monitored.
3. Please make sure the contact ① never touches the measuring glass ④ and the clearance between contact ① and glass ④ is always approx. 1 mm. This clearance can be obtained by turning the contact in the sliding block ⑦.
4. Test the switching characteristic by moving the float ⑤ over and beyond the switching position.
5. Retighten the lock nut ⑥. **Maximum fastening torque is 2 Nm!**

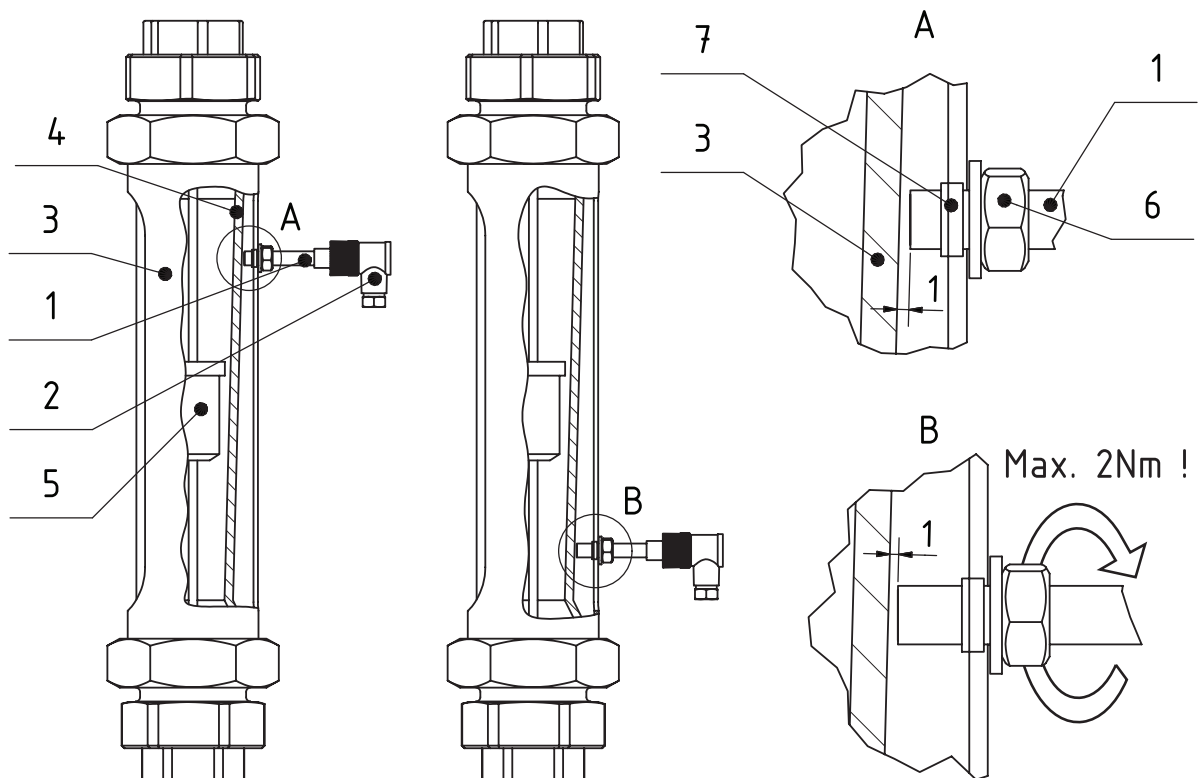

- ① MSK limit value switch
- ② M12 right angle plug
- ③ flow meter
- ④ measuring glass
- ⑤ float
- ⑥ lock nut
- ⑦ sliding block



8 Linear displacement sensor 4 .. 20 mA/0 ... 10V

The linear displacement sensor, based on the Hall effect, delivers an output signal proportional to the height setting of the flow meter.

The signal can be displayed in 4 ... 20 mA or 0 ... 10 V and is used for remote flow rate observation. The sensor is connected via the enclosed M12 x 1 mm connector.

Please notice, that the sensor has a blind zone in the range of 3.7 mA to around 4 mA and performs stable operation only after approx. 4 mA.

8.1 Connection of the linear displacement sensor



The electrical connection of the device must be performed according to the pertinent VDE regulations, as well as the regulations of the local power company.

1. Disconnect electric power from the system before connecting the sensor.
2. Provide a protective circuit of the sensor corresponding to its output.
3. Connect the protective elements suitable for use upstream.
4. The cable connection is done on the enclosed angle connector. The circuit diagram for the sensor is in the following illustration:

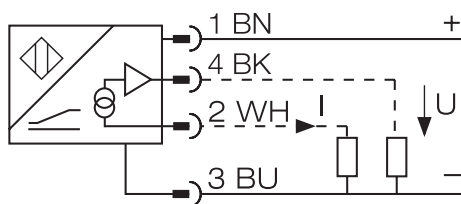

circuit diagram

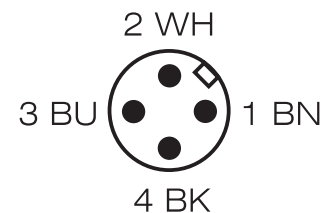

pin assignment



8.2 Adjusting the sensor

The linear position sensor is delivered adjusted to the lowest measuring range point. This corresponds to an output signal of 4 mA.

The remaining measuring range or mA values can be taken from the supplied protocol.

If you want to move the 4 mA value to another measuring range point, move the sensor or the 4 mA value to the requested point.

To do this, loosen the two outer nuts with their lock washers. Next loosen the two stud screws by approximately one turn. Now you can move the sensor to the desired position and tighten the stud bolts and nuts again.

To record the new mA values, move the float to the desired scale lines and note the mA values.



9 Maintenance and cleaning of the flow meter

The device is maintenance-free. Should the glass cone become fouled, the device can be removed from the pipeline as follows.

9.1 Dismantling the glass cone RA 60

1. First dismantle the device by undoing the screw connections, item 3.
2. Take the device out together with the gaskets, item 2.
3. Detach upper head, item 4 together with gasket, item 5 and thrust collar, item 6 from the device. If the float is provided with a guide rod, item 17 remove this completely with the head but without dismantling it any further.
4. Unscrew the lower head, item 4 and remove the gasket and thrust collar.
5. On nonguided floats, the float stops (receptacles) in the measuring glass are either helical springs or inserts made of plastics. Remove these together with the float and make a note of the installation positions and directions.
6. Press the glass cone to one side out of the case. Avoid using sharp pointed tools. Remove the loose rubber ring from the glass cone.
 - The ring remaining on the glass cone does not need to be removed.
7. Clean the glass cone. Do not use abrasive tools or aggressive cleansing agents (wire brush, scouring cleaner, alkaline solutions, acids etc.).

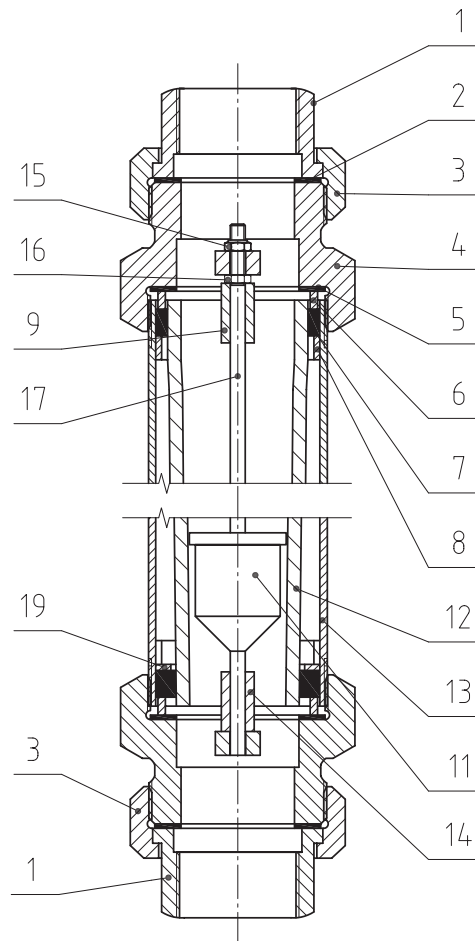

9.2 Assembling the glass cone RA 60

Reassemble in the reverse order of dismantling:

1. Be aware of the original direction of installation and the installation positions.
 - In particular, do not let tools come into direct contact with the glass when inserting the glass cone and jointing the loose rubber ring.
 - In this instance, use water as a lubricant.
2. Inspect all gaskets to see whether they can still be used, and replace if necessary.
3. Align the glass cone so that the markings can be read off through the cutout in the case.

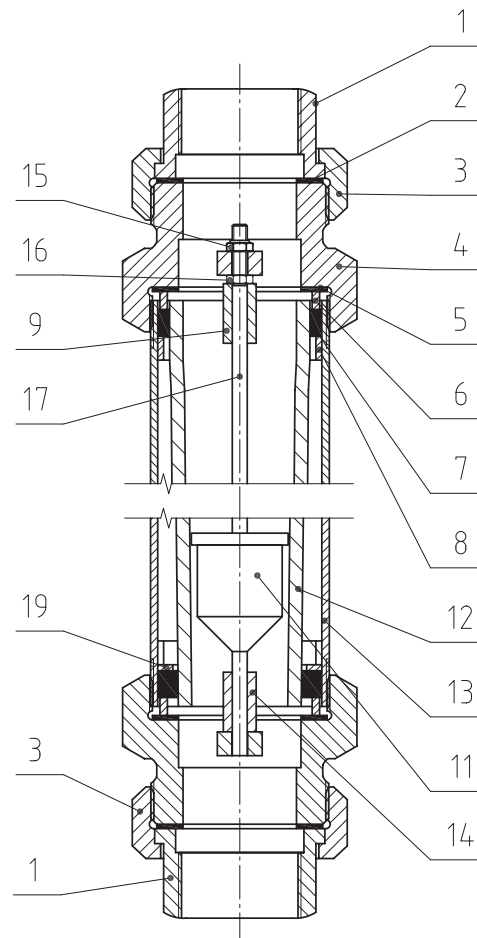

9.3 Replacement of the glass cone RA 60

Proceed as described in section 9.1. and section 9.2

For devices with glass size 6 and smaller, a support disk (20) is additionally installed. This is placed under the sealing ring (7) to prevent it from slipping out. This also applies to customer modifications from glass size 10 to 6 or smaller.

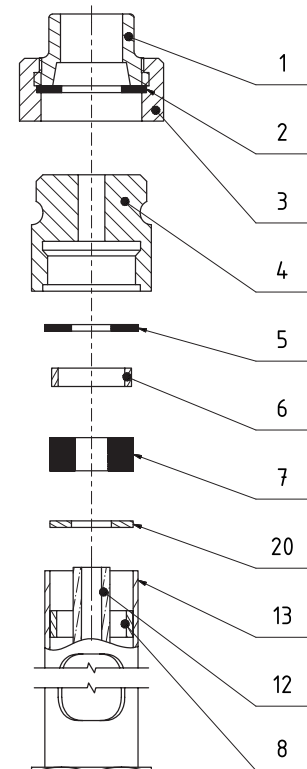



9.4 Dismantling of the glass cone FA 60

1. Remove the device together with the gaskets pertaining to the flanged connections (detach the flanged connections).
2. Dismantle the outer flanges, items 1 and 16.
3. On nonguided floats, the float stops (receptacles) in the measuring glass are either helical springs or inserts made of plastics. Remove these together with the float and make a note of the installation positions and directions.
4. Press the glass cone to one side out of the case. Avoid using sharp pointed tools. Remove the loose rubber ring from the glass cone.
 - The ring remaining on the glass cone does not need to be removed.
5. Clean the glass cone. Do not use abrasive tools or aggressive cleansing agents (wire brush, scouring cleaner, alkaline solutions, acids etc.).

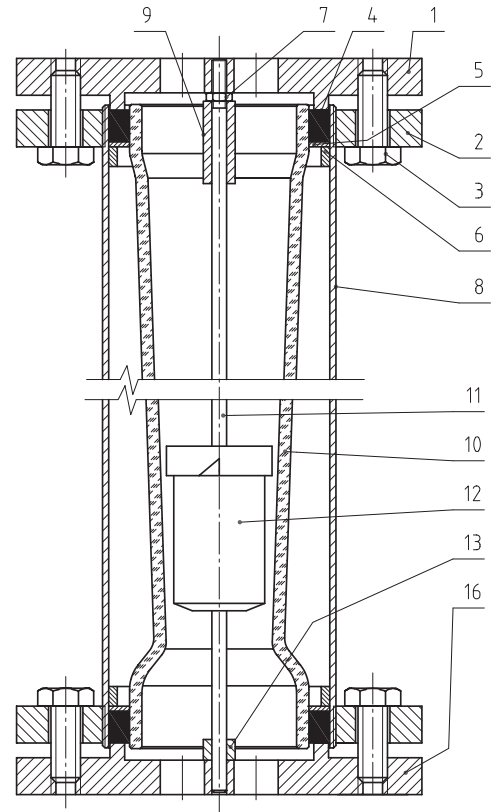

9.5 Installation of the glass cone FA 60

Reassemble in reverse order:

1. Replace the glass cone together with the rubber ring in the case and slip the loose rubber ring over the glass cone.
 - Use water as lubricant (wet rubber ring first).
2. Align the glass cone so that the inscriptions can be read through the cutout in the sleeve.
3. Tighten down the bolts of the outer flanges (in diagonally opposite sequence).

9.6 Replacement of the glass cone FA 60

Proceed as described in section 9.3, 9.4 and 9.5.



9.7 Subsequent installation of a float catcher protective cap

Pressure surges in the measuring line can cause damage or destruction of the float catch. In order to evenly distribute occurring forces and to prevent tearing of the elastomer, RA/FA 60/65/77/87 series variable area flow meters are equipped with a stainless steel float catch protection cap. In the following description, the subsequent installation of the protective cap will be described.

1. Remove the device from the installation site by unscrewing the union nuts ① from the device heads ②.
2. Unscrew the upper head ② of the device together with the guide rod ③ of the device sleeve ④.
3. Unscrew the M5 lock nut ⑤ and pull the guide rod out of the device head.
4. Unscrew the M5 hex nut ⑥ from the guide rod.
5. Insert the catch protection cap ⑦ onto the guide rod, with the large opening pointing to the float catch. The catch protection cap should now enclose the upper part of the elastomer catch ⑧ !

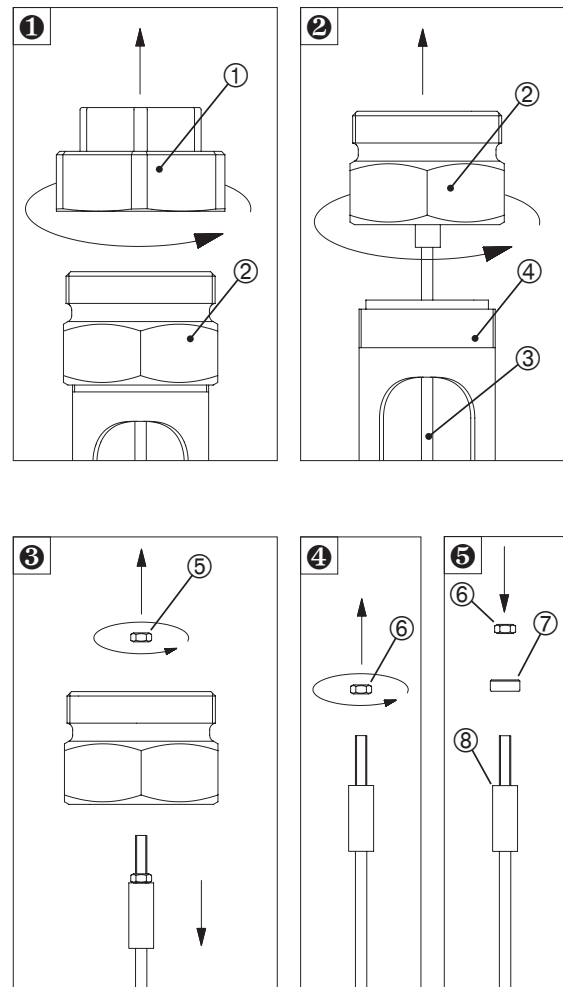



RA 60 / FA 60

Variable area flow meters

6. Tighten the M5 hex nut ⑥ slightly.
7. Insert the guide rod ③ back into the bridge ⑦ of the upper head ② and tighten the M5 locknut ⑤.
8. Insert the guide rod ③ with the upper device head ② back into the float measuring device.
9. Carefully screw the upper head ② back onto the device sleeve ④ and tighten it.
10. Make sure that you insert the lower end of the guide rod ⑧ into the corresponding hole in the lower device head ⑨, otherwise the float ⑩ will not move freely.

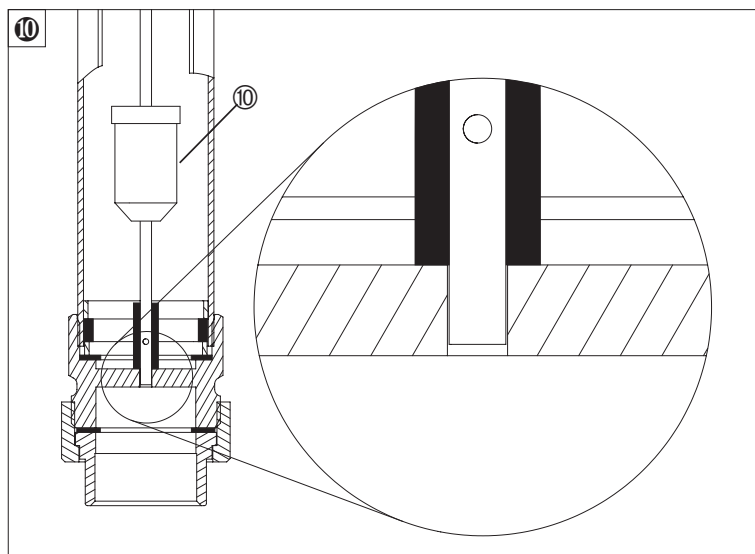
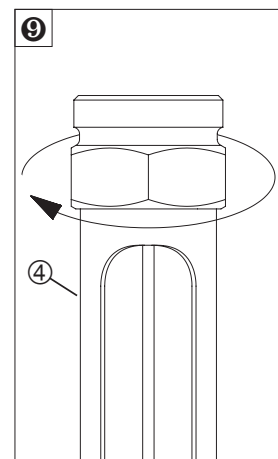
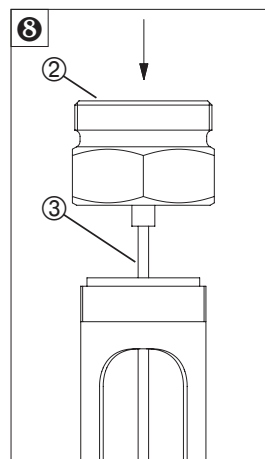
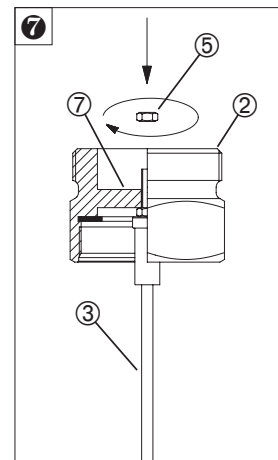
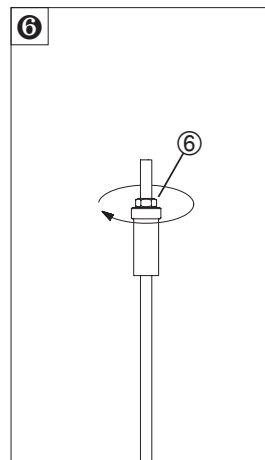



10 Service

All devices with defects or deficiencies should be sent directly to our repair department. In the service area of the Kirchner und Tochter homepage (www.kt-flow.de) you will find the declaration of decontamination as download and more information about returns.

To avoid risks to our employees and the environment, we can only process devices, for which we get a declaration of decontamination certifying that they are safe due to legal regulations. For questions, please contact our sales department, Tel. +49 2065-96090.

11 Disposal

Please help to protect our environment and dispose workpieces in conformity with current regulations resp. continue using them.



12 Technical data

Nominal pressure rating	RA 60: PN 10 at 20 °C FA 60: PN 10 at 20 °C
Max. operating pressure	see table measuring ranges (section 12.2)
Thermal endurance	80 °C, optionally 100 °C
max. ambient temperature	90 °C
Turndown ratio	1:10
Accuracy class	VDE/VDI 3513 page 2 (08/2008)
Error limit (G)	1,6 %
Linear limit (qG)	50 %
Connection RA 60	two-part pipe union: Insert with cylindrical internal thread to DIN EN 10226-1 (ISO 7-1)
Connection FA 60	flange PN 10 acc. to DIN EN 1092-1, other connections on request
Corrosion protection	Epoxy powder coating, traffic blue (RAL 5017) glossy
Corrosion class	C3

12.1 Materials

Protective sleeve	precision steel tube made of P235
Heads RA 60	S355 (size 19), EN-GJL-200 (size 30 – 36), cast aluminium (from size 43)
Threaded joint	malleable cast iron, zinc plated
Flanges FA 60	S355
Measuring glass	borosilicate glass
Splinter shield	perspex
Gaskets	standard: NBR, optionally FKM, EPDM
Floats for liquids ¹⁾	standard: 1.4571 optionally: PVC, PP, PVDF or PTFE
Floats for gases ¹⁾	standard: Aluminium anodized optionally: PVC, PP, PTFE, PVDF or 1.4571
with limit value switches ¹⁾	liquids: 1.4571 with magnetic core gases: PVC with magnetic core

other materials on request

¹⁾ Floats up to size 19 are non guided, floats from size 30 on are guided. Optional size 19 is in guided version available.



12.2 Measuring ranges

Size	Measuring range H ₂ O				Measuring range Air at STP ¹⁾				Max. oper. press [bar] at 20 °C
10	0,1	–	1	l/h	0,3	–	3	l/h	10
	15	–	150	l/h	0,25	–	2,5	m ³ /h	
19	12	–	120	l/h	0,15	–	1,5	m ³ /h	10
	0,12	–	1,2	m ³ /h	1,6	–	16	m ³ /h	
30	0,1	–	1	m ³ /h	1,3	–	13	m ³ /h	10
	0,3	–	3	m ³ /h	3,6	–	36	m ³ /h	
36	0,4	–	4	m ³ /h	4	–	40	m ³ /h	8
	0,8	–	8	m ³ /h	8	–	80	m ³ /h	
43	0,9	–	9	m ³ /h	5	–	50	m ³ /h	8
	1,6	–	16	m ³ /h	16	–	160	m ³ /h	
100	1,6	–	16	m ³ /h	12	–	120	m ³ /h	6
	2	–	20	m ³ /h	28	–	280	m ³ /h	
110	2,5	–	25	m ³ /h	14	–	140	m ³ /h	5
	3	–	30	m ³ /h	44	–	440	m ³ /h	
150	—				30	–	300	m ³ /h	4
					100	–	1000	m ³ /h	
180	—				30	–	300	m ³ /h	3
					150	–	1500	m ³ /h	

¹⁾ at STP: at standard conditions (0 °C and 1013 mbar abs.)

Measuring ranges for other substances and operating conditions on request.



12.3 Dimensions

RA 60					
Size	Pipe union	S	d ¹⁾	L	H
10	Rp ¼	28	12	388	28
	Rp ⅜	32	16	390	
	Rp ½	39	20	393	
19	Rp ½	39	20	405	45
	Rp ¾	48	25	407	
	Rp 1	55	32	415	
30	Rp 1	55	32	415	60
	Rp 1 ¼	67	40	430	
	Rp 1 ½	74	50	436	
36	Rp 1 ¼	67	40	430	75
	Rp 1 ½	74	50	436	
	Rp 2	90	63	446	
43	Rp 1 ½	74	50	440	95
	Rp 2	90	63	446	
	Rp 2 ½	111	75	460	
	Rp 3	131	90	470	
100	Rp 2	90	63	446	115
	Rp 2 ½	111	75	458	
	Rp 3	131	90	470	
110	Rp 2 ½	111	75	462	133
	Rp 3	131	90	474	

¹⁾ d for bonding and welding sleeves

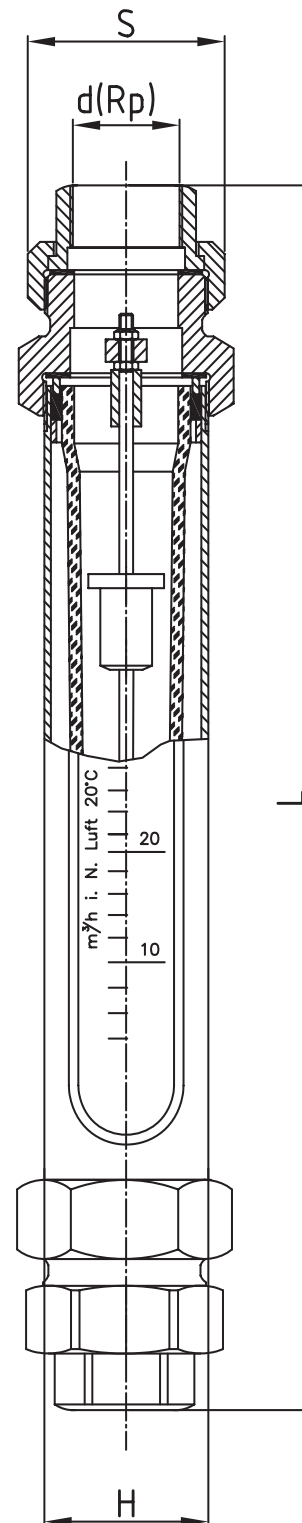



FA 60							
Size	DN	L	H	D	k	Screws Qty.	d ²
10	10	340	28	90	60	4	M12
	15			95	65	4	M12
	20			105	75	4	M12
	25			115	85	4	M12
19	10	340	45	90	60	4	M12
	15			95	65	4	M12
	20			105	75	4	M12
	25			115	85	4	M12
30	25	340	60	115	85	4	M12
	32			140	100	4	M16
	40			150	110	4	M16
36	32	340	75	140	100	4	M16
	40			150	110	4	M16
	50			165	125	4	M16
43	40	340	95	150	110	4	M16
	50			165	125	4	M16
	65			185	145	4	M16
100	65	340	115	185	145	4	M16
	80			200	160	8	M16
	100			220	180	8	M16
110	65	340	133	185	145	4	M16
	80			200	160	8	M16
	100			220	180	8	M16
150	80 ¹⁾	640	178	220	160	8	M16
	100			220	180	8	M16
	125			250	210	8	M16
	150			285	240	8	M20
180	150	640	219	285	240	8	M20
	200			340	295	8	M20

¹⁾ Installation length: 655 mm

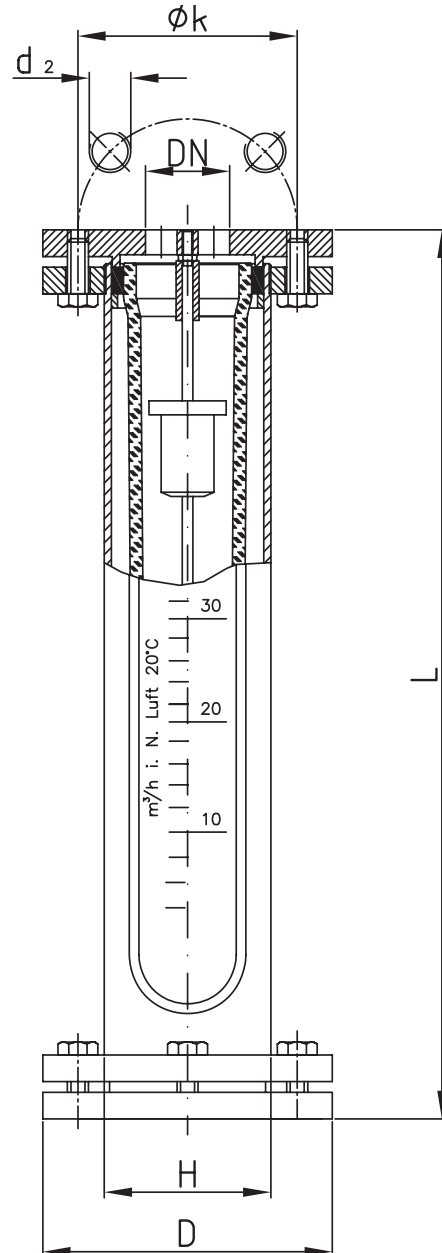



RA 60 / FA 60

Variable area flow meters

RA/FA 60-EM	
Size	A
100	47
110	47

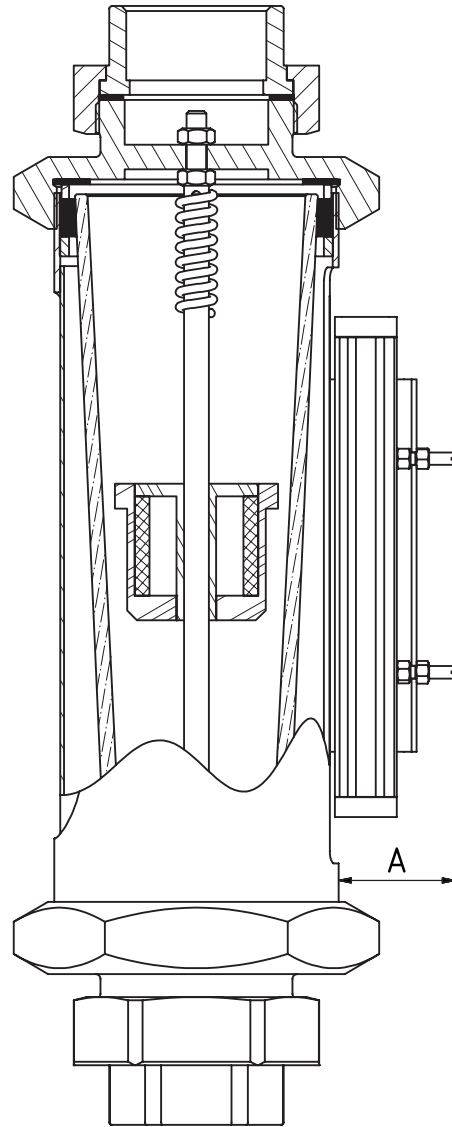

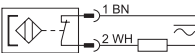
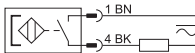
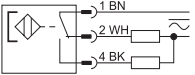

12.4 Limit value switches MSK1/MSK12/MSKW

Design	MSK1	MSK12
Switching voltage	50 V AC/75 V DC	50 V AC/75 V DC
Switching current	max. 0,5 A	max. 0,5 A
Switching capacity	max. 10 W/VA	max. 10 W/VA
Dielectric strength	230 V AC/400 V DC	230 V AC/400 V DC
Temperature range ¹⁾	-20 ... +90 °C	-20 ... +90 °C
Switching function	normally closed	normally open
Connection		
Design	MSKW	
Switching voltage	50 V AC/75 V DC	
Switching current	0,5 A	
Switching capacity	5 W/VA	
Dielectric strength	110 V AC/200 V DC	
Temperature range ¹⁾	-20 ... +90 °C	
Switching function	change over	
Connection		

¹⁾ The thermal endurance of the flow meter is crucial.

Connection via freely configurable right angle plug M12 x 1



12.5 Right angle plug M12 x 1

M12 x 1 Right angle plug	
Connector	field-wireable female connector, M12 x 1, angled
Number of poles	4-pole, A-coding
Contacts	metal, CuZn, optalloy-plated
Contact carriers	plastic, PA, black
Grip	plastic, PBT, black
Seal	plastic, FKM
Degree of protection	IP67 only tightened with screws
External diameter of the cable	4 ... 6 mm
Core cross-section/ Clamping ability	max. 0,75 mm ²
Screw-in thread	PG 7
Connection mode	screw clamp
Mechanical lifespan	min. 50 contact durability
Pollution degree	3
Rated voltage	max. 250 V
Insulation resistance	≥ 108 Ω
Ampacity	4 A
Forward resistance	≤ 8 mΩ
Ambient temperature Connector	-25 ... +85 °C

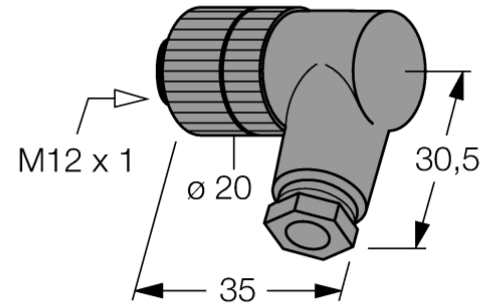

Dimensions

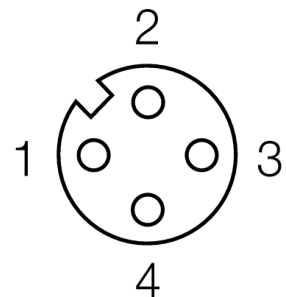

Connection



12.6 Linear displacement sensor

Measurement range	125 mm / 160 mm
Repeatability	≤ 0,1 % from measurement range ≤ dependent upon position sensor
Linearity deviation	≤ 1 % v.E.
Temperature drift	≤ ± 0,006 %/K
Ambient temperature ¹⁾	-25 ... +65 °C
Operating voltage	15 ... 30 V DC
Residual ripple	< 10 % U _{ss}
Idle current	≤ 15 mA
Rated insulation voltage	< 0.5 kV
Short circuit protection	yes
Fail-safe circuit/reverse polarity protection	yes/complete
Output function ²⁾	Four-wire, analogue output
Voltage output / → Load resistor	0 ... 10 V / ≥ 4,7 kΩ
Current output / → Load resistor	4 ... 20 mA / ≤ 0,4 kΩ
Recovery time at output	< 15 ms
Sampling rate	200 Hz
Type	Rectangular, Q25L
Dimensions	166 / 201 x 35 x 25 mm
Housing material	Aluminium
Material of active surface	Plastic, PC-GF20
Connection	Plug Connector, M12 x 1
Vibration resistance	55 Hz (1 mm)
Shock resistance	30g (11 ms)
Protection class	IP67
Operating voltage display	LED, green
Measurement range display	LED, yellow, position sensor in detection range
Connection diagram ²⁾	

¹⁾ The thermal endurance of the flow meter is crucial.

²⁾ A two-wire version is also available on request.

12.7 Low-Voltage Directive

Above 50 V AC/75 V DC, contacts are subject to the EU Low Voltage Directive. The user is required to verify their use accordingly.



RA 60 / FA 60

Variable area flow meters



Kirchner und Tochter

Durchflussmesstechnik seit 1951



The devices from **Kirchner und Tochter** have been tested in compliance with applicable EC/EU CE-regulations of the European Community.

The respective declaration of conformity is available on request. Subject to change without notice. The current valid version of our documents can be found at www.kt-flow.de.

The **Kirchner und Tochter** QM-System is certified in accordance with DIN EN ISO 9001:2015. The quality is systematically adapted to the continuously increasing demands.