

# **Installation and Operating Instructions**

## **Differential-Pressure Flow Meter** **DDM** **DDM Ex**



## Contents

1	Foreword .....	3
2	Safety .....	3
2.1	Symbol and meaning .....	3
2.2	General safety directions and exemption from liability .....	3
2.3	Intended use .....	3
2.4	Information for Operator and operating personnel .....	4
2.5	Regulations and guidelines .....	4
2.6	Notice as required by the hazardous materials directive .....	4
2.7	Additional information on explosion protection.....	4
3	Transport and storage .....	5
4	Installation .....	5
4.1	Preparatory work prior to installation.....	5
4.2	DDM with screw connections .....	6
4.3	DDM mounted between flanges .....	7
4.4	DDM with internal thread .....	8
5	Start-up.....	9
6	Service .....	9
7	Disposal.....	9
8	Technical data .....	10
8.1	Connection .....	10
8.2	Materials .....	10
8.3	Measuring ranges for water .....	11
8.4	Measuring ranges for air .....	12
8.5	Dimensions DDM mounted between flanges DDM-DN .....	13
8.6	Dimensions DDM with screw connections DDM-Rp .....	13
8.7	Dimensions DDM with female thread DDMGi/DDM-Ga .....	13
9	Additional information for use in hazardous areas .....	14
9.1	Main safety features.....	14
9.2	Installation and setup .....	15
9.3	Start-up .....	16
9.4	Service .....	16
9.5	Dismantling .....	17
9.6	Maintenance.....	17
10	Appendix.....	18
10.1	Manufacturer declaration acc. to directive 2014/34/EU .....	18
10.2	Declaration of conformity .....	19

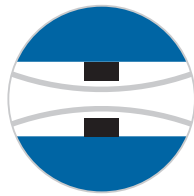

## 1 Foreword

These Installation and Operating Instructions are applicable to devices of Series DDM. Please follow all instructions and information given for installation, operation, inspection and maintenance. The Instructions form a component part of the device and should be kept in an appropriate place accessible to the personnel in the vicinity of the location. Where various plant components are operated together, the operating instructions pertaining to the other devices should also be observed.

## 2 Safety

### 2.1 Symbol and meaning



Safety notice

This symbol is placed against all directions/information relating to occupational health and safety in these Installation and Operating Instructions and draws attention to danger to life and limb. Such notices should be strictly observed.

### 2.2 General safety directions and exemption from liability

This document contains basic instructions for the installation, operation, inspection and maintenance of the variable area flow meter. Non-observance of these directions can lead to hazardous situations for man and beast and also to damage to property, for which Kirchner und Tochter disclaims all liability.

The operator is required to rule out potentially hazardous situations through voltage and released media energy.

### 2.3 Intended use

The DDM differential-pressure flow meters are designed for measuring and monitoring the flow of liquids and gases with an appropriate indicator. They may be installed in the pipeline only between flanges or using threaded pipe connections. Straight, unimpeded lengths of pipe runs must be a minimum of 6 x DN (DN=nominal pipe diameter) upstream of the location and a minimum of 4 x DN downstream of the location. The required version of the DDM device should be selected on the basis of the nominal diameter and nominal pressure at the location as well as the type of medium.



## 2.4 Information for Operator and operating personnel

Authorized installation, operating, inspection and maintenance personnel should be suitably qualified for the jobs assigned to them and should receive appropriate training and instruction. All persons charged with assembly, mounting, operation, inspection and maintenance duties must have read and understood the operating instructions. Gaskets in contact with the fluid product must be replaced after all maintenance and repair work.

## 2.5 Regulations and guidelines

In addition to the directions given in these Installation and Operating Instructions, observe the regulations, guidelines and standards, such as DIN EN and for specific applications, the codes of practice issued by DVGW (gas and water) and VdS (underwriters) or the equivalent national codes and applicable national accident prevention regulations.

## 2.6 Notice as required by the hazardous materials directive

In accordance with the law concerning handling of waste (critical waste) and the hazardous materials directive (general duty to protect), we would point out that all flow meters returned to Kirchner und Tochter for repair are required to be free from any and all hazardous substances (alkaline solutions, acids, solvents etc.).



Make sure that devices are thoroughly rinsed out to neutralize hazardous substances.

## 2.7 Additional information on explosion protection

Only devices of type DDM Ex are suitable for use in hazardous areas. For detailed information see chapter 9.

### **Danger!**



Danger of explosion may occur if handled incorrectly. Installation, setup, commissioning and maintenance of explosion-protected equipment may only be carried out by personnel trained in explosion protection („competent person“).

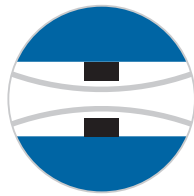

### **3 Transport and storage**

Always use the original packing for transport, handling and storage. Protect the device against rough handling, coarse impact, jolts etc.

## **4 Installation**

### **4.1 Preparatory work prior to installation**

Provide the pipe ends at the installation point with the external pipe thread or flanges respectively (Type series DN) appropriate to the device. Make sure the installation space at the installation point is in keeping with the dimensions given in the dimensional drawing and the table in the Technical Data chapter



## 4.2 DDM with screw connections

The measuring device is screwed into the pipeline between two inserts that are supplied with the device. The straight, unimpeded inlet and outlet runs should be a minimum of 6 x DN upstream and a minimum of 4 x DN downstream of the location. Between the inserts, leave a gap of  $L1 + 4\text{mm}$  for the gaskets. The dimensions of  $L1$  can be found in section 8.6.

- Cut appropriate threads on the pipe ends (3) (in accordance with the order). Make sure that the ends of the pipe are in alignment.
- Unscrew the union nuts (1) from the DDM and slide these on to the pipe ends, with the thread facing towards the device (2).
- Screw the insert (4) to the pipe ends using suitable packing material.
- Position the DDM together with the two gaskets (5) between the pipe ends and tighten the union nuts.

 **Inaccurate measurements are possible due to incorrect installation position. Observe the flow direction during installation (see arrow (6) on the device (2))**

- Pay attention to the direction of flow (see arrow (6) on the device).

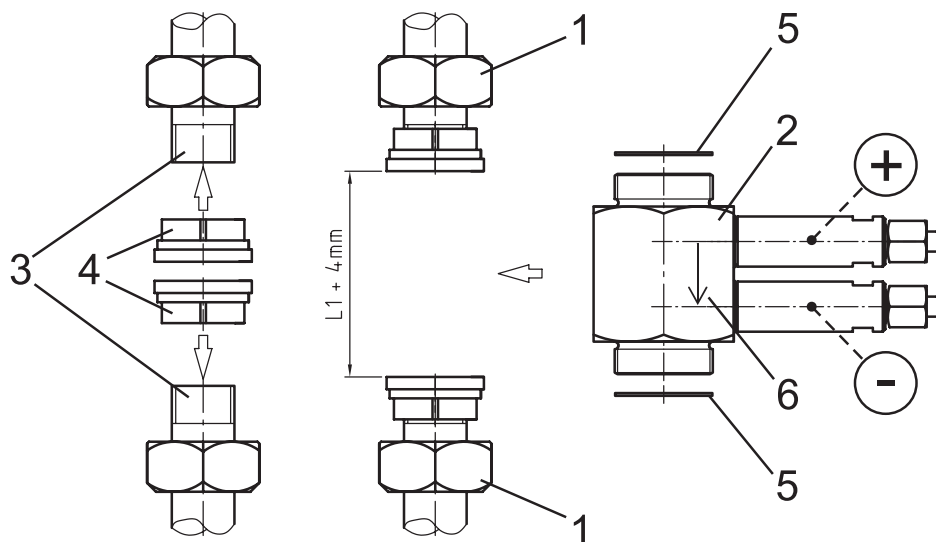

1. Union nut
2. DDM
3. Pipe ends (customer side)
4. Inserts
5. Gaskets
6. Arrow for installation direction

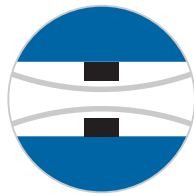

### 4.3 DDM mounted between flanges

The flow meter is mounted between flanges to DIN EN 1092-1 (Type 11 or Type 13). The straight, unimpeded pipe run should be a minimum of 6 x DN upstream and a minimum of 4 x DN downstream of the location. The distance between the flanges should be 55 mm for the ring plus twice the thickness of the gaskets to be used. Make sure that the flanges are in alignment and the sealing faces are parallel to each other. Check that the flanges at the location agree with the details given in the order (standard and pressure rating).

- The distance between the flanges should be  $55 \text{ mm}^* + 2 \times t$  (thickness of gaskets used).
- Fit half of the screw connections to the interflange connection,
- Mount the orifice, together with the gaskets fitted on both sides, between the two prepared flanges.
- Assemble the remaining screw connections.
- When tightening the screws, make sure that orifice and gaskets are concentric and in alignment with the pipeline.
- Fasten all screw connections uniformly in diagonally opposed sequence.

\*(Standard length)  
Length can vary order related. Please compare with your order!

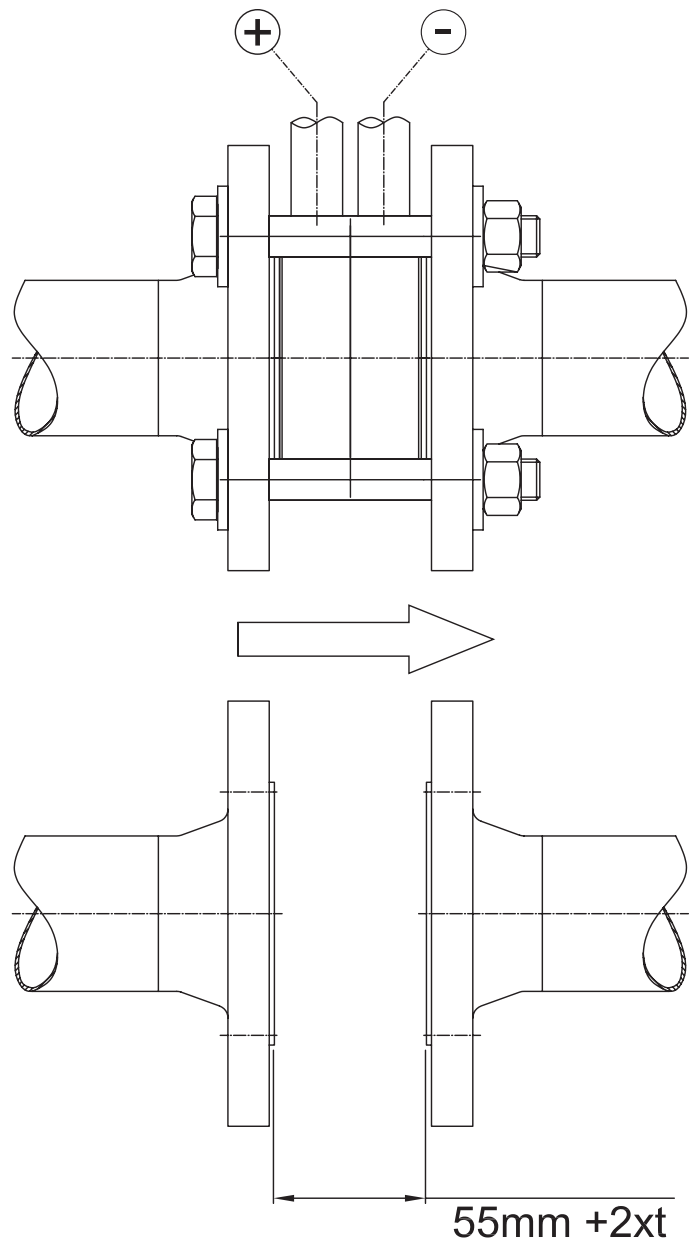



## 4.4 DDM with internal thread

As a screw-in pipe fitting, the device is screwed into the pipeline. The straight, unimpeded length of pipe run needs to be a minimum of  $6 \times \text{DN}$  (DN= nominal diameter) upstream of the installation location and a minimum of  $4 \times \text{DN}$  downstream of the location. Provide a gap of L1 between the pipe ends. The dimension for L1 is given in section 8.7.

- Provide the pipe ends with suitable threads (in accordance with the order). Make sure that the pipe ends are in alignment.
- Screw the flow indicator to the pipe ends using suitable packing material.



**Incorrect measurements are possible when device is installed in incorrect mounting position. When installing, be aware of the flow direction (see arrow on device).**

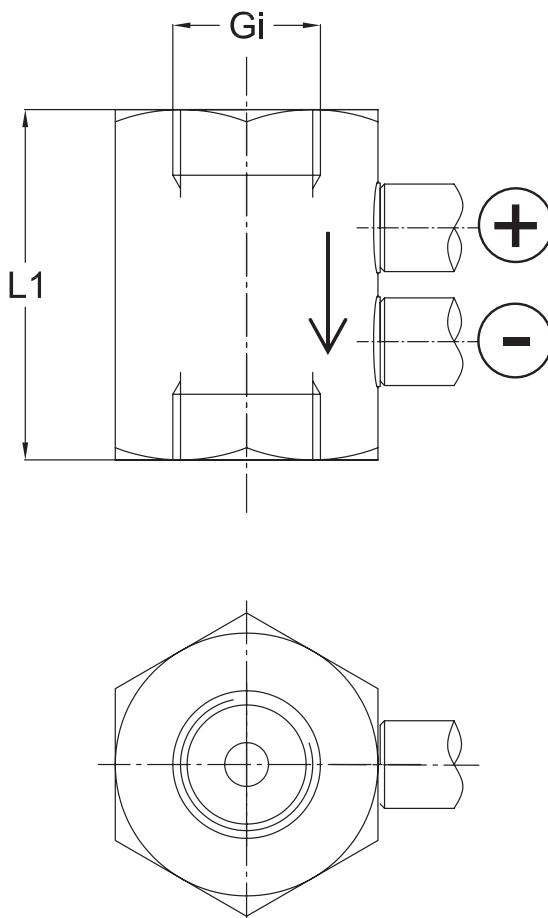

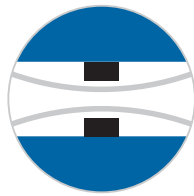

## 5 Start-up

- The flow meter must have been properly installed before it is started up.
- An electrical or mechanical differential-pressure meter/monitor or a transmitter must be connected to the measuring lines before start-up.
- The measuring lines are labelled with (+) and (–) symbols.
- Make sure that the measurement device is installed in accordance with this label.
- If no measuring devices are to be connected up, fit blanking plugs to the measuring connections.
- After start-up, check the leak-tightness of the orifice.

## 6 Service

All devices with defects or deficiencies should be sent directly to our repair department. In the service area of the Kirchner und Tochter homepage ([www.kt-flow.de](http://www.kt-flow.de)) you will find the declaration of decontamination as download and more information about returns.

To avoid risks to our employees and the environment, we can only process devices, for which we get a declaration of decontamination certifying that they are safe due to legal regulations. For questions, please contact our sales department, Tel. +49 2065-96090.

## 7 Disposal

Please help to protect our environment and dispose workpieces in conformity with current regulations resp. continue using them.



## 8 Technical data

### 8.1 Connection

Measuring principle	differential pressure at the orifice
Differential pressure <sup>1)</sup>	air: 5 - 1000 mbar H <sub>2</sub> O: 100 - 1000 mbar
Pressure loss	ca. 40 % of differential pressure
Pressure resistance DDM	PN 16 (Please note the pressure resistance of the display unit)
Perm. ambient temperature	-10 ... +70 °C
Perm. medium temperature <sup>2)</sup>	standard -10 ... +70 °C max. 130 °C (insulated line) optionally HT design above 130 °C
Between flanges (DN)	PN 10 or PN 16 in accordance with DIN EN 1092-1, shape A & B
Pipe union (Rp)	two-part pipe fitting: insert with cylindrical internal thread acc. to DIN EN 10226-1 (ISO 7-1)
Internal thread (Gi)	cyl. internal fastening screw thread in accordance with DIN EN ISO 228
External thread (Ga)	cyl. external fastening screw thread in accordance with DIN EN ISO 228 T1.

<sup>1)</sup> other differential pressure on request

<sup>2)</sup> medium must not freeze

### 8.2 Materials

<b>DDM-DN</b>	
Ring	S355, optionally 1.4571
Corrosion protection	Epoxy powder coating, traffic blue (RAL 5017) glossy
Corrosion class	C3
Orifice	1.4571
<b>DDM-Rp, -Gi, -Ga</b>	
Pipe union	malleable cast iron, zinc plated (Rp only)
Orifice	brass
Seals	NBR, others on request

other materials on request

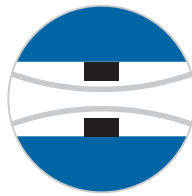

### 8.3 Measuring ranges for water

Connection: screwed pipe union/internal thread/for external thread

Rp / Ga / Gi	smallest measuring range [m <sup>3</sup> /h] H <sub>2</sub> O			largest measuring range [m <sup>3</sup> /h] H <sub>2</sub> O		
1/4"	0,05	-	0,3	0,2	-	1,2
3/8"	0,05	-	0,4	0,4	-	2,3
1/2"	0,1	-	0,7	0,75	-	4,5
3/4"	0,2	-	1,3	1,4	-	8,5
1"	0,35	-	2	2,25	-	13,5
1 1/4"	0,6	-	3,5	4	-	24
1 1/2"	0,85	-	5	5,35	-	32
2"	1,25	-	7,5	8,65	-	52

other measuring ranges on request

Connection for in-between flange assembly

DN	smallest measuring range [m <sup>3</sup> /h] H <sub>2</sub> O			largest measuring range [m <sup>3</sup> /h] H <sub>2</sub> O		
40	0,85	-	5	5,35	-	32
50	1,2	-	7	8,7	-	52
65	2	-	12	13	-	78
80	3	-	18	19,7	-	118
100	4,7	-	28	30,7	-	184
125	7,3	-	44	48	-	288
150	10,7	-	64	68,8	-	413
200	18,8	-	113	122,5	-	735

other measuring ranges on request



## 8.4 Measuring ranges for air

Connection: screwed pipe union/internal thread/for external thread

Rp / Ga / Gi	smallest measuring range [m <sup>3</sup> /h] air <sup>1)</sup>			largest measuring range [m <sup>3</sup> /h] air <sup>1)</sup>		
¼	0,5	-	3	1,3	-	8
⅜	0,8	-	5	2,3	-	14
½	1,0	-	6	3,5	-	21
¾	1,3	-	8	7,5	-	45
1	2,0	-	12	9	-	54
1 ¼	4,0	-	24	18	-	108
1 ½	5,8	-	35	25	-	150
2	8,3	-	50	45	-	270

<sup>1)</sup>at STP (0 °C and 1013 mbar) in-between ranges possible

Connection for in-between flange assembly

DN	smallest measuring range [m <sup>3</sup> /h] air <sup>1)</sup>			largest measuring range [m <sup>3</sup> /h] air <sup>1)</sup>		
40	5,8	-	35	25	-	150
50	9	-	54	45	-	270
65	13,5	-	81	83	-	500
80	20	-	120	125	-	750
100	35	-	210	180	-	1080
125	60	-	360	292	-	1750
150	75	-	450	433	-	2600
200	125	-	750	667	-	4000

<sup>1)</sup>at STP (0 °C and 1013 mbar) in-between ranges possible

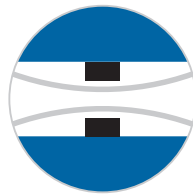

**DDM**

Differential pressure flow meters

### 8.5 Dimensions DDM mounted between flanges DDM-DN

DN	d <sub>4</sub>	L
40	88	55
50	102	55
65	122	55
80	138	55
100	158	55
125	188	55
150	212	55
200	268	55

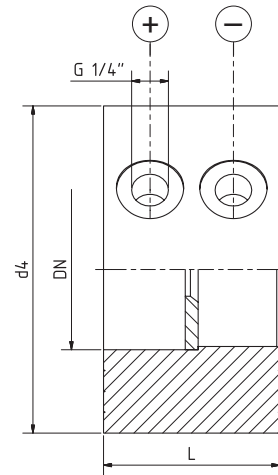

### 8.6 Dimensions DDM with screw connections DDM-Rp

Rp	L <sub>1</sub>	L <sub>2</sub>	SW
1/4	80	124	41
3/8	80	128	46
1/2	80	128	46
3/4	80	128	50
1	80	136	60
1 1/4	80	146	70
1 1/2	80	149	70
2	90	164	85

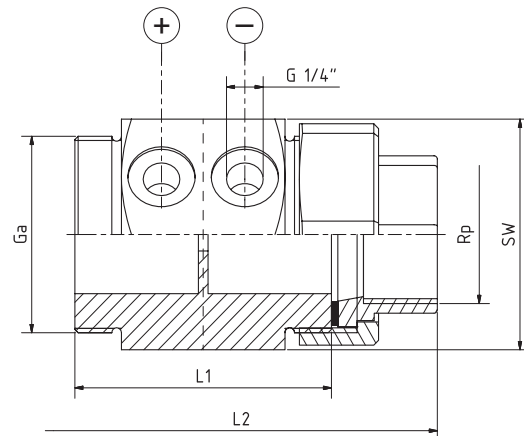

### 8.7 Dimensions DDM with female thread DDMGi/DDM-Ga

Gi	Ga	L <sub>1</sub>	SW
1/4	3/4	80	41
3/8	3/4	80	46
1/2	1 1/8	80	46
3/4	1 1/4	80	50
1	1 1/2	80	60
1 1/4	2	80	70
1 1/2	2 1/4	80	70
2	2 3/4	90	85

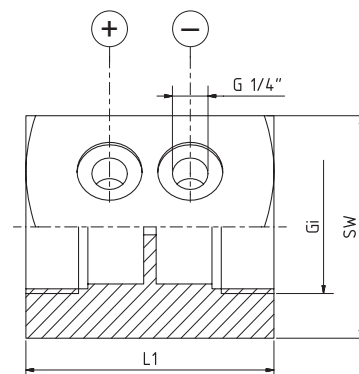



## 9 Additional information for use in hazardous areas

### 9.1 Main safety features

#### Category/Zone

DDM Ex differential pressure flowmeters are designed for use in category 3 according to directive 2014/34/EU and suitable for use in zone 2 - see also sections 10.1 to 10.2 in the appendix.

#### Types of protection

The devices of this type do not have a type of ignition protection as they do not have or cause any ignition sources of their own when used as intended.

#### Temperature classes

Maximum allowable ambient / medium temperatures of differential pressure flowmeters of the DDM Ex series in °C for use in temperature class T6-T1:

The table considers the following parameters to determine the permissible temperature class:

- Ambient temperature  $T_{amb}$
- Medium temperature  $T_m$

#### Temperature classes T6 - T1

$T_{amb}$ : < 40 °C

$T_m$ : < 70 °C

#### Operating pressure

See chapter 8.1.

#### Static electricity

With differential pressure flowmeters, it is generally possible for the electrostatic field generated inside the housing to penetrate the outside of the device. The devices of the DDM Ex series must therefore be permanently earthed (see section 9.2).

#### Danger!



Incorrect connection may result in explosion hazards. The operator is responsible for continuing the complete earthing of the process line.

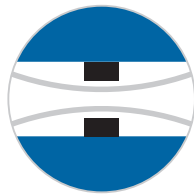

### Static discharge

Surfaces can be electrostatically combustibly charged during cleaning. These surfaces are marked with the shown adhesive label.

**Caution! Measures against static charging**

Do not rub the plastic surface.  
Clean surfaces only with damp cloth.

The marked locations may be cleaned only with a damp, lint-free cloth.

In addition, caution should be taken not to rub against these surfaces with clothing, since static charge can occur at any time.

Dust deposits on the housing are also to be removed with a damp cloth. The deposits must not exceed a thickness of 3 mm.

## 9.2 Installation and setup

**Danger!**

Danger of explosion can result from incorrect handling. Installation, set up, commissioning and service of explosion protected operating material must only be performed by personnel trained in explosion protection („competent person“).

The differential pressure flowmeter must be grounded.

See also the illustration in section 9.2.

If the device is not sufficiently electrostatically grounded via the process line, an additional ground connection must be made using the marked ground connection on bottom of the device. The connection only guarantees an electrostatic connection of the device and does not meet the requirements for an equipotential bonding connection.



## Ground connection

The following figure shows a schematic diagram of the connection of the earthing cable with the process line.

This grounding cable must be connected to the process line before commissioning.

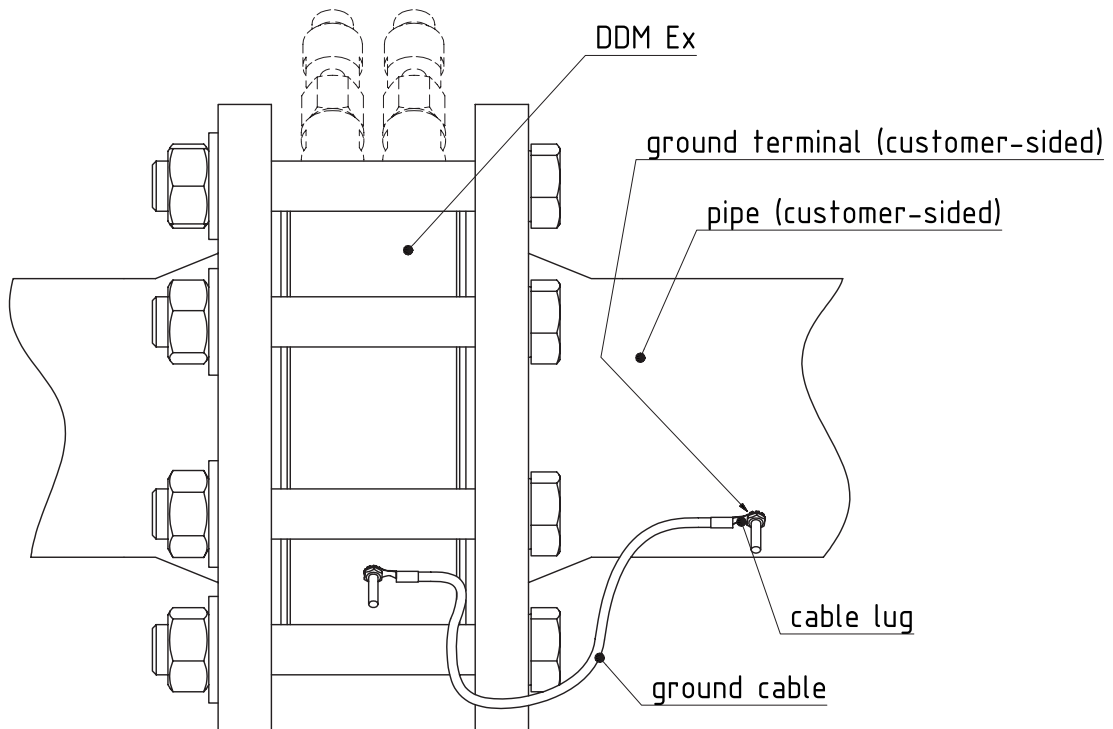

## 9.3 Start-up

Before start-up, the following tests are to be performed:

1. Qualification testing for sufficient corrosion resistance to the measuring media of the materials used for measurement parts and the used sealing materials.
2. Electronically ground the measurement equipment.  
(Also see the illustration under section 9.2)

## 9.4 Service

### Danger!



Danger of explosion can result from incorrect handling. The service of explosion protected operating material must only be performed by personnel trained in explosion protection.

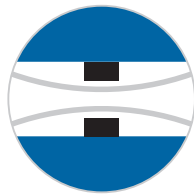

The differential pressure flowmeters of type:

- DDM Ex

are maintenance free under normal operating conditions and proper usage.

In unfavourable operating conditions, the measuring function may be impaired by soiling. In this case a cleaning is to be performed according to the installation and operating instructions. Alternatively, the device can be sent to Kirchner und Tochter for cleaning.

Systems in potentially explosive areas must be regularly inspected for their proper condition. The following tests must be performed regularly:

- Visual inspection of the housing and connection pieces for damage or corrosion.
- Check the measurement parts for leaks.
- Include the differential pressure flowmeter in the regular pressure tests of the process line.
- Dust deposits on the equipment must not exceed a thickness of 3 mm.
- The equipment is to be thoroughly cleaned with a damp cloth.

## 9.5 Dismantling

### Process connections

#### **Danger!**

Danger of injury due to media escaping under pressure. The lines in which the variable area flow meter is installed are to be discharged before disassembly.



Depending on the medium, damage to the respiratory system or the skin may occur, for example. Uncontrolled discharge of residual liquid from the measurement piece is to be avoided.

For environmentally critical measuring media, all parts which have been in contact with the media are to be decontaminated carefully after removal. Removal and installation is the responsibility of the operating company.

## 9.6 Maintenance

Maintenance, which is relevant to safety in regards to explosion protection, is only to be performed by the manufacturer, their agents or supervised by authorised technicians.



## 10 Appendix

### 10.1 Manufacturer declaration acc. to directive 2014/34/EU



**Kirchner und Tochter**  
Durchflussmesstechnik seit 1951

#### Manufacturer declaration acc. to directive 2014/34/EU

**A. Kirchner & Tochter GmbH, Dieselstr. 17, 47228 Duisburg, Germany**

We declare under sole responsibility that the products

#### **DDM Ex** **Differential pressure flow meter**

were subjected to a hazard analysis in accordance with Directive 2014/34/EU.

**The Differential pressure flow meters do not fall under the scope of Directive 2014/34/EU (ATEX) because they do not have potential sources of ignition and cause no potential ignition sources in hazardous areas if used according to the intended purpose.**

For operation in hazardous areas, the valid installation and operating instructions must be observed.

The DDM Ex can be used in explosion protection zone 2 for gas temperature class T6.

#### **Supplementary notes:**

- The device must be included in the equipotential bonding at the point of installation. The device is equipped with a grounding connection for this purpose.
- A maximum dust deposit of 3 mm on the surface is permissible. If this value is exceeded, the unit can be cleaned.
- Cleaning may only be carried out with a damp cloth.

#### **Applied standards:**

- EN 13463-1 Non-electrical equipment for use in potentially explosive atmospheres
- EN 1127-1 Explosive atmospheres - Explosion prevention and protection - Part 1: Basic concepts and methodology

Duisburg 12.11.2018

Torsten Krawczyk  
Geschäftsführer/  
Managing Director

i.V. Stanislaw Wosmiller  
Konstruktion/  
Engineering

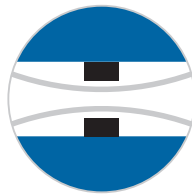

**DDM**

Differential pressure flow meters

## 10.2 Declaration of conformity



**Kirchner und Tochter**  
Durchflussmesstechnik seit 1951



EU-Konformitätserklärung  
EU-Declaration of Conformity

A. Kirchner & Tochter GmbH, Dieselstr. 17, 47228 Duisburg, Deutschland

Wir erklären hiermit unter alleiniger Verantwortung, dass folgende Produkte  
We declare herewith under sole responsibility that the products

**DDM Ex**  
**Differenzdruck-Messblende / Differential Pressure Flow meter**

konform sind mit den Schutzzielen der Richtlinien des europäischen Parlaments und des Rates (soweit zutreffend).  
are in conformity with the protection requirements of the European Parliament and of the Council (as far as applicable).

Der geforderte Sicherheits- und Gesundheitsschutz wird erfüllt in Übereinstimmung mit den harmonisierten Standards oder den angeführten technischen Normen (soweit zutreffend):  
The stipulated safety and public health safety requirements are fulfilled in accordance with the harmonised standards or mentioned technical specifications (as far as applicable):

Richtlinie / Directive		Harmonisierte Normen/ Harmonised standards	Angewendete nationale Normen und Vorschriften/ Applied national standards and specifications		
2014/68/EU	Druckgeräterichtlinie Pressure Equipment Directive	EN 12266-1:2012-06	-		
Die Geräte fallen nicht unter den Anwendungsbereich der Richtlinie 2014/34/EU (ATEX). Sie haben keine eigenen Zündquellen. Die oben genannten Geräte dürfen in Zone 2, Explosionsgruppe IIC eingesetzt werden, wenn die Bedingungen und Hinweise der Einbau- und Betriebsanleitung und der Herstellererklärung erfüllt werden. The devices do not fall within the scope of the directive 2014/34/EU (ATEX). They do not have their own ignition sources. The devices mentioned above may be used in Zone 2, explosion group IIC if the conditions and notes of the installation and operating instructions and the manufacturer's declaration are fulfilled.					
Kennzeichnung / Marking					
Richtlinie/ Directive	Konformitäts- bewertung/ Assessment	Registrier Nr./ EC Type Approval	Kategorie/ Category	Benannte Stelle/ Notified body	Nr./ No.
2014/68/EU	A2	CE-0085BN0052	I & II	DVGW	CE 0085
	Art 4.3 SEP	-	Art 4.3	-	-

Duisburg, 15.11.2018

Torsten Krawczyk  
Geschäftsführer/  
Managing Director

i.V. Stanislaw Wosmiller  
Konstruktion/  
Engineering

A. Kirchner & Tochter GmbH  
Fon: +49 2065 9609-0 · Fax: +49 2065 9609-22  
Geschäftsführende Gesellschafterin: Almuth Anne Römer  
Amtsgericht Duisburg

Dieselstraße 17 · D-47228 Duisburg  
www.kt-flow.de · info@kt-flow.de  
Geschäftsführer: Torsten Krawczyk  
HR B 6458



# Kirchner und Tochter

Durchflussmesstechnik seit 1951

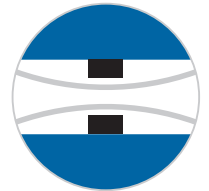

The devices from **Kirchner und Tochter** have been tested in compliance with applicable EC/EU CE-regulations of the European Community.

The respective declaration of conformity is available on request. Subject to change without notice. The current valid version of our documents can be found at [www.kt-flow.de](http://www.kt-flow.de).

The **Kirchner und Tochter** QM-System is certified in accordance with DIN EN ISO 9001:2015. The quality is systematically adapted to the continuously increasing demands.