



Design and applications

Measuring units RA 87 and FA 87 are based on the variable area float principle. In pipelines the RA 87 is installed by means of pipe unions and the FA 87 is mounted between flanges. The borosilicate glass measuring cone is located inside a protective stainless steel tube with an inspection window. All parts in contact with the measured medium are made of stainless steel 1.4571.

VA flow meters RA 87 and FA 87 are most suitable for the flow measurement of transparent liquids and gases. Each unit is customized with a scale specific for the medium to be measured. RA 87 and FA 87 are mainly used in the chemical industry, in water treatment plants, in the food industry, and in other plant engineering applications.

By installation of electrical limit value switches, which are adjustable throughout the entire measuring range, this devices can be used as detectors.

By installing an linear displacement sensor an output signal can be generated which is proportional to the height setting of the flow meter.

Our technical documents provide a detailed explanation of the function and measuring principle of VA flow meters.

RA 87 / FA 87



- **calibrated borosilicate measuring cone**
- **armature completely made of stainless steel**
- **perspex half-shell as shatter protection**
- **reliable due to simple mode of operation**
- **scales specific for the media to be measured**
- **optionally**
 - **limit value switches**
 - **analogue output 4 ... 20 mA**
 - **explosion-proof design**
 - **PVDF lining for flow measurement of aggressive fluids**





RA 87 / FA 87

Variable area flow meters

Type series

RA 87 G	with female thread
RA 87 Rp	with two part pipe union
FA 87	with flange connections
RA / FA 87-MSK1	with switching switch (normally open)
RA / FA 87-MSK12	with switching switch (normally closed)
RA / FA 87-MSKW	with switching switch (change over)
RA / FA 87-EM	with analogue output 4 ... 20 mA
RA / FA 87... Ex	explosion-proof design

Technical data

Nominal pressure rating	FA 87: PN 10 at 20 °C RA 87: PN 10 at 20 °C
Max. operating pressure	see table measuring ranges on page 3
Temperature resistance	80 °C, optionally: 100 °C
Ambient temperature	90 °C
Measuring range	1:10
Accuracy class	VDE/VDI 3513 page 2 (08/2008)
Error limit (G)	1,6 %
Linear limit (qG)	50 %
Connection RA 87	G: cylindrical female fastening thread acc. to ISO 288 Rp: two-part pipe union: insert with cylindrical internal thread acc. to DIN EN 10226-1 (ISO 7-1)
Connection FA 87	flanges PN 10 acc. to DIN EN 1092-1, others (ANSI, JIS, ...) on request

Materials

Protective tube	1.4301
Heads RA 87	1.4571, optionally: PVDF ²⁾
2-part fitting	1.4571, optionally: PVDF ²⁾
Flanges FA 87	1.4571, optionally: with PVDF inlay ²⁾
Measuring cone	borosilicate glass
Splinter shield	perspex
Seals	standard: FKM optionally: EPDM, FFKM, silicone, perlast
Floats for liquids ¹⁾	standard: 1.4571 optionally: Hastelloy C4
Floats for gases ¹⁾	standard: PTFE optionally: PVC, PVDF, PP, aluminium anodized
with limit switches ¹⁾	standard: 1.4571 with metal core for air: PVC with metal core optionally: PP, PVDF, PTFE (each with magnetic core)
Special design ²⁾	protection of all parts in contact with media

other material on request

¹⁾ Floats of small sizes are nonguided. Size 30 and larger: Partly with guided float. Optionally sizes 9,5 (without limit value switches only) and 19 are deliverable. A detailed table is available on request.

²⁾ PVDF lining: All wetted parts, except the measuring glass, are made from PVDF.

Dimensions

RA 87 with female thread						
Size	G	DN	SW1 ²⁾	d ¹⁾	L	H
9,5	¼	10	20	12	266	25
	⅜	15		16		
19	½	15	40	20	366	44,5
	¾	20		25		
	1	25		30		
30	1	25	55	32	366	60
	1 ¼	32		40		
36	1 ¼	32	65	40	366	70
	1 ½	40		50		
43	1 ½	40	82	50	366	89
	2	50		63		

¹⁾ only with PVC gluing sleeves and PP-, PVDF welding sleeves

²⁾ only with sst (1.4571) design

RA 87 with tube fittings								
Size	(1.4571) Design				Versions			H
	Thread	L	SW2	DN	d ¹⁾	L (PVC)	L (PP, PVDF)	
9,5	Rp ¼	306	27	10	16	302	304	25
	Rp ⅜	309	32	15	20	305	305	
	Rp ½	314	41					
19	Rp ½	414	41	15	20	405	405	44,5
	Rp ¾	416	50	20	25	411	409	
	Rp 1	422	55	25	32	417	413	
30	Rp 1	422	55	25	32	423	419	60
	Rp 1 ¼	428	70	32	40	432	424	
	Rp 1 ½	429	75	40	50	442	430	
36	Rp 1 ¼	428	70	32	40	432	424	70
	Rp 1 ½	429	75	40	50	442	430	
	Rp 2	433	90	50	63	456	438	
43	Rp 1 ½	429	75	40	50	448	436	89
	Rp 2	433	90	50	63	462	444	

¹⁾ only with PVC gluing sleeves and PP-, PVDF welding sleeves

FA 87									
Size	DN	L	H	D	d4	k	Screws		d2
							Qty.	Thread	
9,5	10	260	25	90	40	60	4	M12	14
	15			95	45	65	4	M12	14
19	10	360	44,5	90	40	60	4	M12	M12
	15			95	45	65	4	M12	14
	20			105	58	75	4	M12	14
	25			115	68	85	4	M12	14
30	25	360	60	115	68	85	4	M12	14
	40			150	88	110	4	M16	18
36	40	360	70	150	88	110	4	M16	18
	50			165	102	125	4	M16	18
43	50	360	89	165	102	125	4	M16	18
	65			185	122	145	4	M16	18

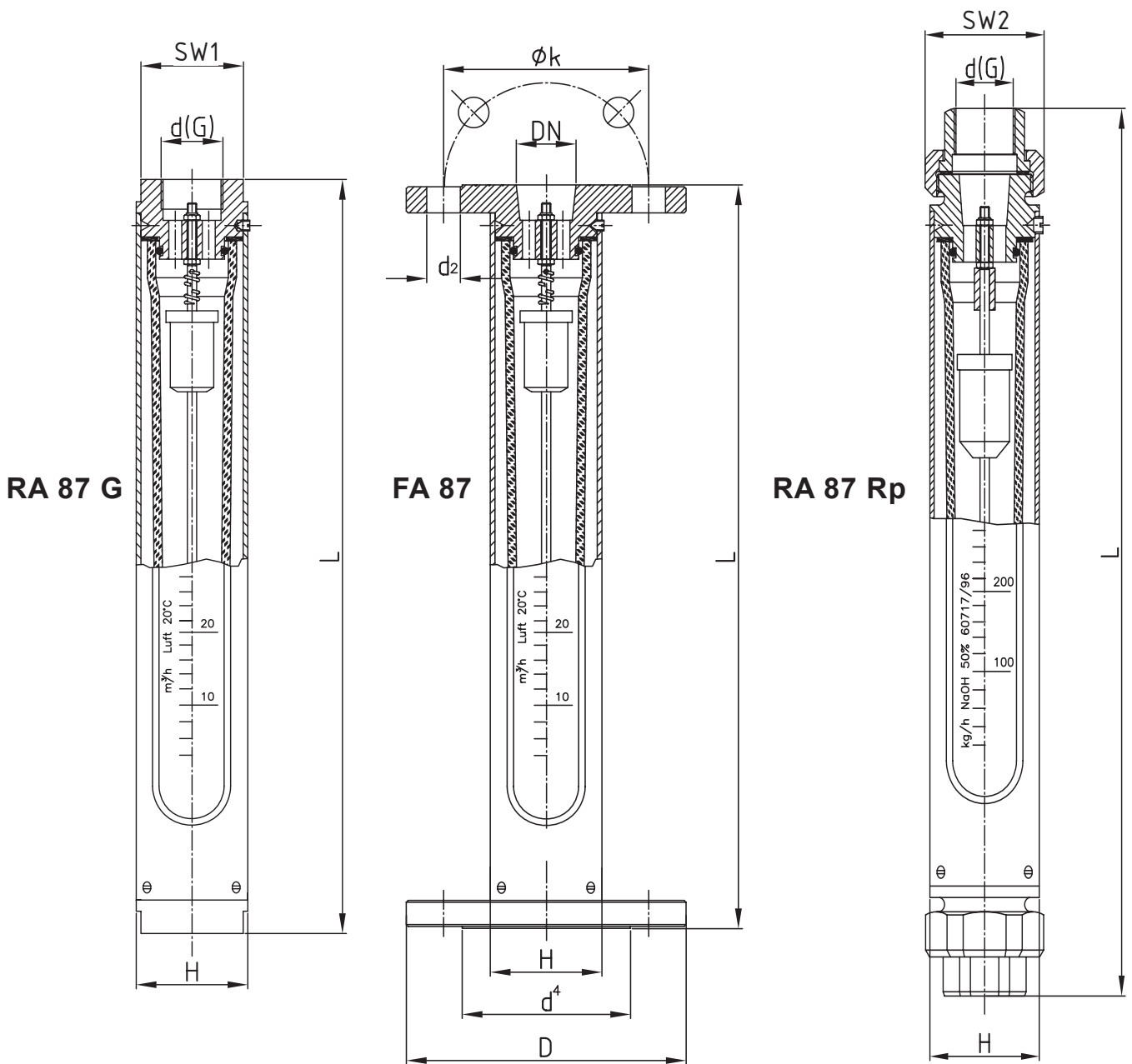

Measuring range (min. and max. measuring range; all intermediate measuring ranges are possible)

Size	measuring range H ₂ O		measuring range air at STP ¹⁾			Connections		max. operating pressure in bar at 20 °C
	Float all Materials		Float PTFE, PVDF	Float PVC, PP	RA 87 female thread	FA 87 Flange connection DN		
9,5	0,5	5 l/h	8	8	¼	10	10	
	20	200 l/h	0,28	2 m³/h	⅜	15		
19	12	120 l/h	0,15	1,5 m³/h	½	15	10	
	0,12	1,2 m³/h	1,6	16 m³/h	¾	20		
						25		
30	0,1	1 m³/h	1,2	12 m³/h	1	25	10	
	0,3	3 m³/h	3	30 m³/h	1 ¼	40		
36	0,4	4 m³/h	3,5	35 m³/h	1 ¼	40	8	
	0,8	8 m³/h	8	80 m³/h	1 ½	50		
43	0,9	9 m³/h	8	80 m³/h	1 ½	50	8	
	1,6	16 m³/h	16	160 m³/h	2	65		

measuring ranges for other substances and operating conditions on request

¹⁾ at STP: at standard conditions (0 °C and 1013 mbar abs.)



RA 87 / FA 87

Variable area flow meters

RA / FA 87-EM

Size	A
9,5	45
19	37
30	45
36	46
43	47

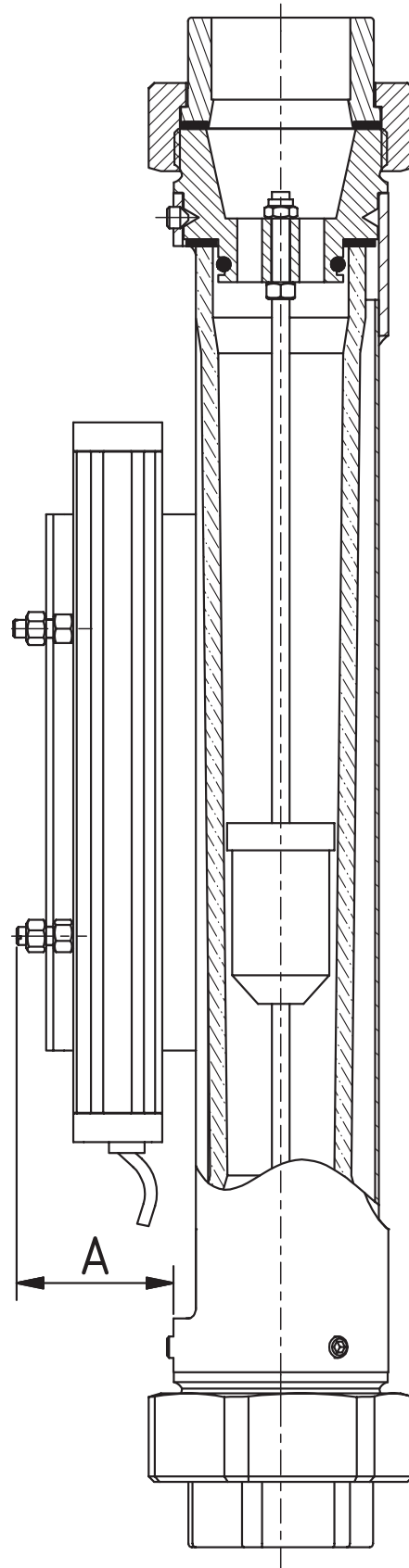

Limit value switches MSK1/MSK12/MSKW

In order to realise a local display with a monitoring function the flowmeter can be equipped with limit value switches.

The limit value switch consists of a connector housing and a bistable reed switch.

A magnet integrated in the float switches this reed switch. The limit value switch is guided in a guide slot on the back of the protective tube and can be adjusted throughout the entire measuring range. In case of inductive or capacitive load applications, e.g. caused by contactors or solenoid valves, uncontrolled current and voltage peaks may occur. In dependence on their geometry such peaks also occur in lines if they exceed a certain length. It is therefore recommended to use an additionally available arc suppression relay "MSR". This increases the switching capacity and avoids the appearance of inductive and capacitive peaks. It thereby ensures a long lifetime of the contact.

Technical data of the limit value switches

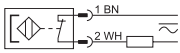
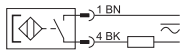
Design	MSK1	MSK12
Switching voltage	50 V AC/75 V DC	50 V AC/75 V DC
Switching current	0,5 A	0,5 A
Switching capacity	10 W/VA	10 W/VA
Dielectric strength	230 V AC/400 V DC	230 V AC/400 V DC
Temperature range ¹⁾	-20 ... +90 °C	-20 ... +90 °C
Switching function	normally closed	normally open
Connection		

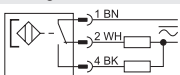
Design	MSKW	
Switching voltage	50 V AC/75 V DC	
Switching current	0,5 A	
Switching capacity	5 W/VA	
Dielectric strength	110 V AC/200 V DC	
Temperature range ¹⁾	-20 ... +90 °C	
Switching function	change over	
Connection		

¹⁾ The thermal endurance of the flow meter is crucial.

Linear displacement sensor EM

The linear displacement sensor based on the Hall principle delivers an output signal proportional to the height setting of the flow meter. This signal can be displayed in 4 ... 20 mA or 0 ... 10 V to realise a remote indication. The sensor is connected via the enclosed M12 x 1 plug.

- Compact Design
- High level of reproducibility
- Measuring range indication via LED
- Most helpful for SPS integration
- Realise remote indication

Please notice that the sensor has a blind zone in the range of 3.7 mA to around 4 mA and only performs stable operation from approx. 4 mA.

Technical Data

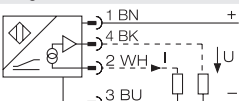
Measurement range [A...B]	160mm, 125mm
Repeatability	≤ 0,1 % from measurement range ≤ dependent upon position sensor
Linearity deviation	≤ 1 % v.E.
Temperature drift	≤ ± 0,006 %/K
Ambient temperature	-25 ... +70 °C
Operating voltage	15 ... 30 V DC
Idle current	≤ 15 mA
Output function	Four-wire, analogue output
Voltage output → Load resistor	0 ... 10 V ≥ 4,7 kΩ
Current output → Load resistor	4 ... 20 mA ≤ 0,4 kΩ
Sampling rate	200 Hz
Connection	Connector, M12 x 1
Protection class	IP67
Operating voltage display	LED, green
Measurement range display	LED, yellow, position sensor in detection range
Connection diagram	

¹⁾ The thermal endurance of the flow meter is crucial.



RA 87 / FA 87

Variable area flow meters

Low Voltage Directive

Above 50 V AC/75 V DC, electrical components are subjected to the EU Low Voltage Directive (LVD). The user is required to verify their use accordingly.

Proper use

The user is responsible for assessing the suitability of the flow meters for his case of application, for use as prescribed and for material compatibility as regards the fluid product used in his process.

The manufacturer shall not be liable for any damage arising from incorrect or improper use of the devices.

Pressure surges can cause glass breakage and should therefore generally be avoided. The limit values given in the data sheet should be observed.

In all other respects we advise following the installation recommendations specified in Code VDI/VDE 3513, Sheet 3.

The equipment from **Kirchner und Tochter** has been tested in compliance with applicable CE-regulations of the European Community. The respective declaration of conformity is available on request. Subject to change without notice. The current valid version of our documents can be found at www.kt-flow.de

The **Kirchner und Tochter** QM-System is certified in accordance with DIN EN ISO 9001:2015. The quality is systematically adapted to the continuously increasing demands.